



Hydro-Logic® Flexi Logger 105 User Manual

Contents

Introduction and general information	5
Main features of the Hydro-Logic® Flexi Logger 105	5
Support website	6
Sales enquiries	7
Warranty	7
Safety and important information	7
Revision history	7
Specification	9
Sensor inputs	9
Sensor power supply	9
Data storage	9
Communications	9
Power	10
Mechanical	10
Key differences over the Flexi Logger 100	12
Rainfall timekeeping	12
Wi-Fi data transfer and local comms	12
Dial out button, magnet switch, and beeper	12
No power button	12
Real time clock backup	13
Measurement priority	13
Storage capacity	13
Lower power consumption	13
Remote firmware update	13
FTP data transfer	13
Getting started	14
Switching the logger on and off	14
Connecting to Timeview	14
Recording test data from the sensor	15
Hardware configuration and installation	16
Device overview	16
Status LED flash patterns	17
Sensors	18
Sensor wiring	18

Vented cables	19
SDI-12 sensors	19
4-20mA sensors.....	24
Tipping-bucket rain gauges	26
Approved sensors	27
Pre-wiring and configuration service	27
Outdoor siting.....	28
Pole top enclosure	28
Antennas.....	30
SIM cards	31
Using your own SIM.....	31
SIM installation	32
Access technology	33
NB-IoT and Cat-M1	34
Batteries	36
Replacing the batteries	37
Lithium battery regulations	38
External power	39
Magnet	39
Configuration with Harvest Software	40
Harvest overview	40
Connecting the device	40
Connecting via Wi-Fi	43
Triggering a dial-out.....	44
Resetting the logger clock with Harvest.....	45
Basic configuration	46
Logger Group and Tag.....	46
Configuring sensors	47
Recording interval	47
Water level with respect to datum	49
Sending data to a server	50
Overview - Timeview.....	50
Overview – Xdq Server	50
Overview - DNP3	50
Overview - FTP Transfer.....	51

Timeview via mobile data modem	51
Timeview via local Wi-Fi.....	51
Other data collection systems	52
Automatic data transfer (mobile data modem).....	56
More frequent data transfer	57
SIM and time zone settings	58
Timeview data collection and configuration	59
Finding your data on Timeview	59
Resetting logger clock with Timeview	61
Alarms	62
Logger alarm configuration	62
Set point and alarm condition	62
Hysteresis	62
Timeview alarm configuration	64
Groups and recipients	64
Message contents	64
Alarm routing	65
End-to-end testing	66
Viewing alarms on plots	67
Maximizing battery life.....	68
PSTI Statement of Compliance (SoC).....	69
EU declaration of conformity	70

Introduction and general information

The Hydro-Logic® Flexi Logger 105 is a *telemetry data logger*. It takes measurements from **single or multi-parameter sensors** at regular intervals (typically every 5 or 15 minutes) and stores this data in internal memory. Using a **mobile data modem**, the Hydro-Logic® Flexi Logger 105 contacts a telemetry server (typically once per day) and transfers data to it.

Main features of the Hydro-Logic® Flexi Logger 105

The main external features of the logger are shown below. (1) Serial number window. There is only one serial number. (2) Status LED and magnet switch location. (3) GORE® breather for sensor connector. (4) External antenna connector. There is also an internal antenna. Switching is automatic. (5) Ventilated sensor connector. (6) Wired comms and external power connector.



The main internal features are shown below: (1) SIM for mobile data modem. (2) Dial-out/Wi-Fi button. (3) Battery connector. (4) Battery pack (Lithium or Alkaline).

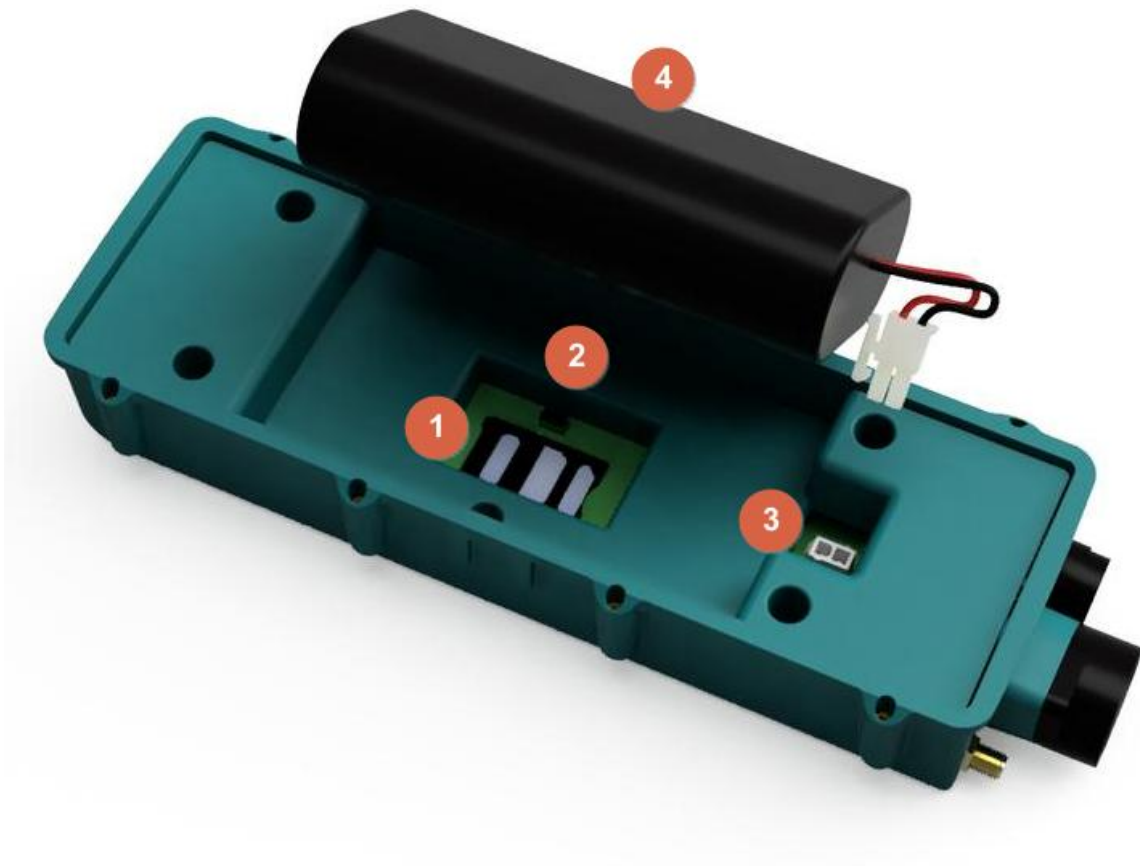

This manual is designed to help you gain a thorough understanding of the operation of this equipment. Hydro International recommends that you read this manual completely before placing the equipment in service.

Support website

For technical assistance with any of our products, please contact our technical support team at:

hydro-int.com/LoggerSupport

If it is necessary to return the equipment to us for service / repair, please follow the shipping instructions provided by technical support. Be sure to include a note describing the issue. This will aid in the prompt return of the equipment.

Sales enquiries

For logger, sensor, Timeview and accessory sales and our pre-wiring and sensor configuration service, contact:

enquiries@hydro-int.com

Hydro International welcomes feedback that would improve products or the information presented in this manual.

Hydro International is continually improving its products and reserves the right to change product specifications without notice.

Warranty

The warranty terms for this product can be found at



www.hydro-int.com/LoggerSupport

The Hydro-Logic® Flexi Logger 105 is suitable for use only with approved sensors, batteries, and communication cables. Connection of any non-approved components could result in unsafe operation or damage to the logger and will immediately void the warranty.

Safety and important information

If this equipment is used in a manner not specified by the manufacturer, the protection provided by the equipment may be impaired.

Throughout this manual, any important safety considerations are highlighted as follows:

	<p>Caution warns you of a potential hazard. If you do not read and follow the instruction, the product could be damaged, or data could be lost.</p>
	<p>Note Highlights important information in using the product</p>
	<p>Battery disposal Information related to correct disposal of batteries.</p>

Revision history

0.90	07 Feb 2020	T Campbell	First version
0.91	11 Feb 2020	T Campbell	Amended after comments
0.92	20 March 2020	T Campbell	FTP transfer documented, minor amendments
0.93	14 Sep 2020	J Drummond	Added Preferred Technology section and External Antenna selection comment

1.0	15 Sep 2020	T Campbell	Images updated; draft status removed.
1.01	12 Nov 2020	T Campbell	Cover screw torque changed to 0.4 N·m
1.02	17 Nov 2020	J Drummond	Added NB-IoT and Cat-M1 section and updated Harvest screenshots
1.03	20 July 2021	T Campbell	Recommendations added for antenna clearance, power up timing and magnet choice. Note about triggering a dial-out before level setting added.
1.04	9 March 2022	T Campbell	Updated to suit Standards and Directives.
1.05	3 October 2022	T Campbell	Update to suit firmware 2.42
1.06	30 March 2023	T Campbell	Advice on NB-IoT and Cat-M1 updated. Manufacturer's address updated.
1.07	10 January 2024	T Campbell	Updated with Timeview 3 screenshots.
1.08	21 November 2024	T Campbell	PSTI Statement of Compliance added
1.09	1 October 2025	T Campbell	Battery part numbers and photos added
1.10	12 December 2025	J Drummond	Timeview, DNP3 and FTP key features added

Specification

Sensor inputs

4-20mA input (Pin 2)	<ul style="list-style-type: none"> • 50-ohm resistance • 1V loop burden at 20mA • 16-bit resolution • 0.1 % accuracy • Transient protection
SDI-12 input (Pin 1)	<ul style="list-style-type: none"> ▪ 32 channels total, up to 8 sensor addresses.
Digital input 1 (Pin 1)	<ul style="list-style-type: none"> ▪ 1s rainfall tip timing resolution ▪ 65000 event counts ▪ 650Hz max frequency ▪ 1K ohm internal pull-up
Digital input 2 (Pin 2)	<ul style="list-style-type: none"> • 1s rainfall tip timing resolution • 65000 event counts • 650Hz max frequency • 1K ohm internal pull-up

Sensor power supply

Power output (Pin 3)	<ul style="list-style-type: none"> ▪ Switched 12V ▪ 120mA output current ▪ Configurable warm-up
----------------------	--

Data storage

Storage capacity	<ul style="list-style-type: none"> ▪ 119700 16-bit readings total divided over the enabled channels.
Channel structure	<ul style="list-style-type: none"> ▪ Up to 32 channels with 16-point look-up tables for engineering value conversion.
Storage intervals	<ul style="list-style-type: none"> ▪ 1m 2m 5m 10m 15m 30m 1h 2h 3h 4h 6h 8h 12h (10s 30s for test purposes only) ▪ Storage interval for each channel can be set independently. ▪ Data is recorded at cardinal points.

Communications

Transport	<ul style="list-style-type: none"> ▪ Internal GPRS/NB-IoT/LTE-M mobile data modem ▪ Wi-Fi module for local configuration AND data transport ▪ Local RS232 connection
Protocols	<ul style="list-style-type: none"> ▪ Modbus ASCII ▪ DNP3 ▪ FTP (IP modem comms only)

Power

Batteries	<ul style="list-style-type: none"> Internal 96Wh Alkaline pack or Internal 187Wh Lithium pack
External	<ul style="list-style-type: none"> 12V lead-acid or 9-24V DC supply

Mechanical

Connectors/switches	<ul style="list-style-type: none"> 1 Sensor connector plug with 4 screw terminals 1 external power and local comms connector (combined) 1 sensor vent with Gore protective patch 1 external mobile data antenna with SMA socket 1 dial-out magnetic reed switch/internal button
Dimensions (mm)	<ul style="list-style-type: none"> W 87 D 63 L 259
Construction	<ul style="list-style-type: none"> Polycarbonate/ABS 3-part injection moulded enclosure. O-ring seals on all external mating surfaces. All connectors back-potted. Stainless steel bracket for surface mounting
Protection Notes	<ul style="list-style-type: none"> IP68: will withstand 1.2m immersion in water for 48 hours without significant ingress. <ol style="list-style-type: none"> All connectors must be mated or have sealing caps fitted. data communications may not function when immersed. gauge-pressure based level sensors are not accurate when logger enclosure is submerged
Operating limits	<ul style="list-style-type: none"> -40 - +70°C, 0 - 100 % RH, Altitude < 2000m

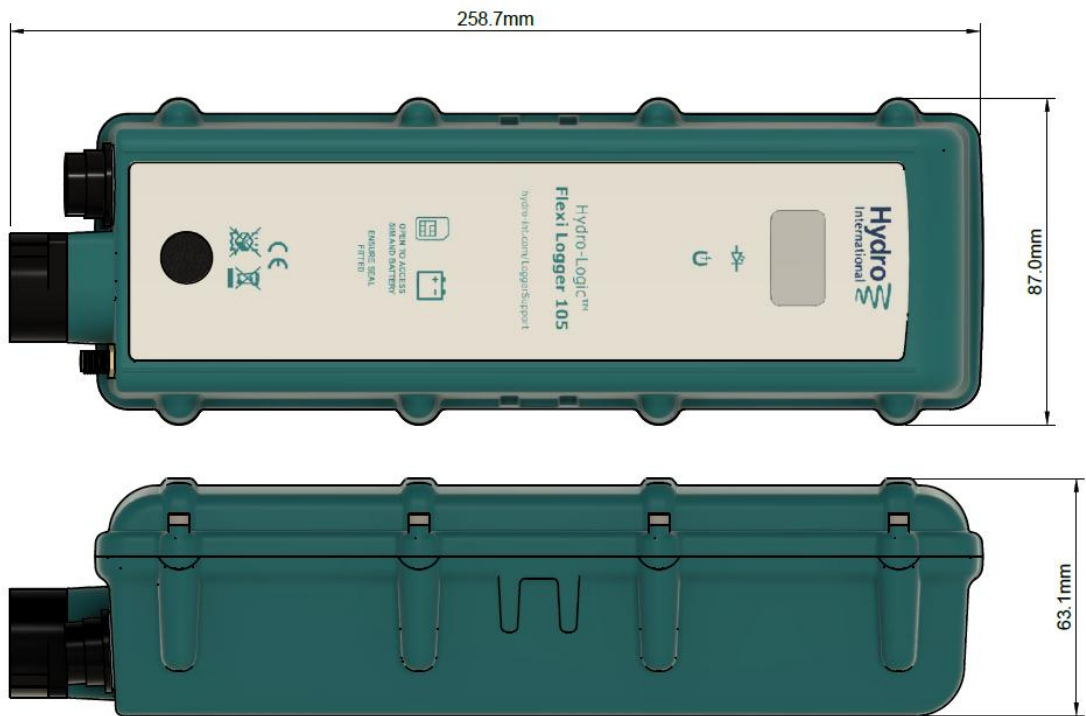

Key differences over the Flexi Logger 100

Feature	Flexi Logger 100	Flexi Logger 105
Rainfall timestamp resolution	2 seconds	1 second
Modem type	3G and GPRS	4G (NB-IoT/LTE-M) and GPRS
Wi-Fi transfer and local comms	No	Yes
Dial out	External button	Magnet/Internal button
Power control	External button	Connect battery
RTC backup on battery change	None	10 minutes
Storage capacity, 16-bit readings	29768	119700
Channels	8	32
Firmware update	Local comms	Local and remote (OTA)
Standard protocols	Modbus ASCII	Modbus ASCII, DNP3, FTP

Rainfall timekeeping

Rainfall tip timestamps are now recorded with 1-second resolution. Other rainfall functions, including intensity alarms, function as before.

Wi-Fi data transfer and local comms

The built-in Wi-Fi module can be configured like a modem, so the Flexi Logger 105 logger can check-in over Wi-Fi. If this option is configured, Wi-Fi will be tried first, before the mobile data modem is used. If Wi-Fi check-in is successful, the mobile data modem is not used. Note that the telemetry server IP address and port must be accessible from the Wi-Fi access point the logger is using. See [Timeview via local Wi-Fi](#).

The Wi-Fi module can also be used for local configuration. This can be activated by long-pressing the dial out button (or magnet switch) until two beeps are heard. This creates a local hot spot which laptops can connect to. Once connected, Harvest can access the logger via IP to perform data transfer and configuration without the use of a local serial cable. See [Connecting via Wi-Fi](#).

Dial out button, magnet switch, and beeper

Dial outs can be triggered locally by holding a [magnet](#) near the LED until a single beep is heard (there is a reed switch below the LED). If you don't have a magnet, you can open the enclosure and press the dial out button beside the SIM holder.

Long-pressing the button or holding the magnet near for longer (until a second beep is heard) will activate the Wi-Fi hot spot for local configuration.

No power button

Connect the battery to power the logger. There is no power button.

Real time clock backup

The logger clock continues to work for 10 minutes after a battery has been removed. Batteries can be replaced without needing to reset the logger clock providing the logger is not without power for more than 10 minutes.

Measurement priority

Sensor measurements takes priority during communications to avoid flat spots on traces where readings are repeated after long comms sessions.

The Flexi Logger 105 continues to measure and store data at the correct points during data communications session.

Storage capacity

Total capacity is 4 X greater than the Flexi Logger 100, and there is a maximum of 32 channels instead of 8.

Lower power consumption

Modern architecture and power supply design significantly reduce the power consumption over the Flexi Logger 100. Alkaline batteries are used more efficiently than with the Flexi Logger 100. There is no HLC in the Flexi Logger 105.

Remote firmware update

Firmware updates can be done OTA (over the air) via the mobile data modem, or locally via Wi-Fi or local wired comms.

Firmware is only applied after a successful, complete transfer, and once the firmware has been correctly decrypted. The logger continues to run the old firmware after an unsuccessful update attempt and does not get “stuck on the bootloader”.

FTP data transfer

The Flexi Logger 105 can be configured to transfer CSV data via FTP using the mobile data modem. The password-protected ftp server must be supplied by the client. See [FTP Transfer](#).

Getting started

These instructions assume

- You are unfamiliar with the Hydro-Logic® Flexi Logger 105
- You have purchased the logger with a [Timeview](#) package, including SIM
- You have ordered the logger with a sensor
- You have ordered the [Pre-wiring and configuration service](#)

The instructions cover the *most important aspects of logger operation*. They should be carried out **before the logger is installed on site**.

Switching the logger on and off

The logger is shipped in the OFF state. There is a battery in the enclosure, but it is not plugged in. See [Replacing the batteries](#), and connect the battery before proceeding.

The logger is now ON. You should see a blue LED flash every eight seconds. There are other patterns of LED activity, which are described in [Status LED flash patterns](#).

You can switch the logger off by unplugging the battery.



Allow 30s to power up before configuring. If you are storing the logger, disconnect the battery.

Note that the internal clock stops when the battery is disconnected for more than 10 minutes, but the configuration and stored data are preserved. You need to reset the logger clock after it is switched on so that data from the sensor is correctly time-stamped. This can be done either by [Resetting logger clock with Timeview](#) or [Resetting the logger clock with Harvest](#)

Connecting to Timeview

With the logger switched on, use a serial cable and Harvest to send a dial out command. See [Triggering a dial-out](#).

The logger will then begin a series of steps to call out to Timeview. Progress can be followed using the [Status LED flash patterns](#), or you can just wait for a few minutes until the red, blue and green flashing has stopped and the logger has gone back to a *single blue flash every 8s*.

Now see [Finding your data on Timeview](#) – you should be able to see that your logger has connected successfully.

If the mobile data signal is poor, the logger will try several times to transfer data to Timeview, so there is no need to press the dial-out button more than once.

Recording test data from the sensor

If you have ordered the [Pre-wiring and configuration service](#), the sensor can be immediately connected to the to the large SCA connector (5) on the logger body.



If you need to wire your own sensor, see the section on [Sensors](#) for more information.

Once the sensor is connected, you should ensure that the clock is reset (either by [Resetting logger clock with Timeview](#) or [Resetting the logger clock with Harvest](#)). This will clean any blank data points that were recorded with no sensor connected, and ensure that data points from the sensor are correctly time-stamped.

Now leave the logger to record some data. The logger will be configured to take measurements every 5 or 15 minutes, so leave it for half an hour or so.

Finally, either press the dial-out button to send data to Timeview or read the logger with Harvest. *You should now see data points from your sensor(s) in the Harvest plot or the Timeview Logger Profile.*

Hardware configuration and installation

Device overview



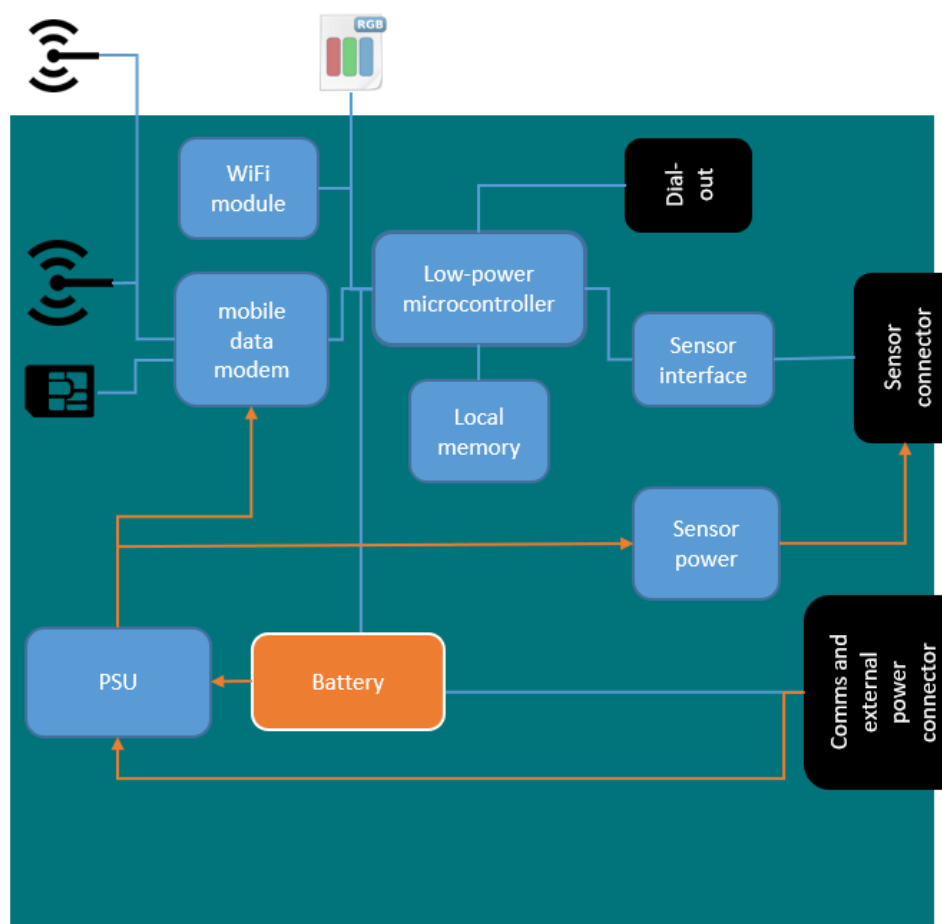





Refer to the block diagram below. The Hydro-Logic® Flexi Logger 105 is controlled by a low-power microcontroller. There is a sensor interface and storage on local memory for the logger configuration and typically several months of time-series data.



A mobile data modem (or Wi-Fi module) is used to transfer data to a remote data collection system. The mobile data modem includes a standard SIM interface.

Status LED flash patterns

The Hydro-Logic® Flexi Logger 105 is fitted with status LEDs on the main board and on the display board. The status of the logger is shown by the colour and flash sequence.

	Blue flashes 5 seconds apart: modem off, normal logging
	Yellow flash: dial-out initiated (one beep)
	White flash: Wi-Fi hotspot enabled (two beeps)
	White flash from normal logging: Wi-Fi check-in
	Green flashes: logger sending commands to modem (not data)
	Single long blue: start of modem data communications
	Red-blue flashes: Modbus communications
	Red flash: rain fall count activity
	Regular long green: logger running bootloader, waiting for firmware

Sensors

The Hydro-Logic® Flexi Logger 105 can be used with many sensor types. Sensors fall into these general categories:

- SDI-12 sensors
- 4-20mA sensors
- Tipping bucket rain gauges and other digital sensors

Sensor wiring

Sensors connect to the Hydro-Logic® Flexi Logger 105 via the SCA connector (5):



Each Hydro-Logic® Flexi Logger 105 is supplied with a 4-way plug with screw terminals for connecting the sensor wires. Replacement plugs are available – part no **PDA1100.3195**

Wiring diagrams for most compatible sensors can be found in Harvest Software when configuring the logger.

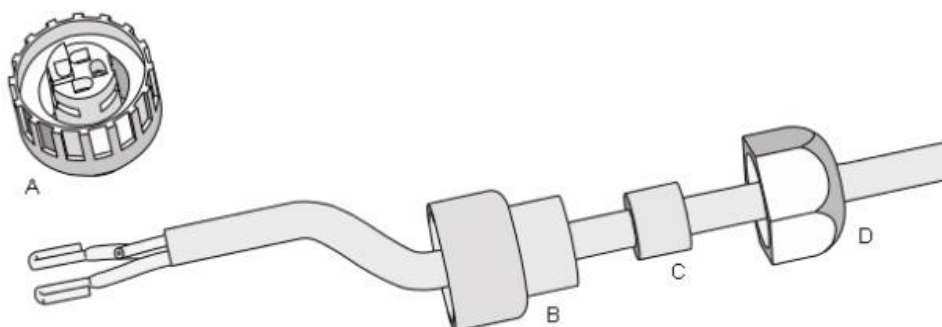

Fitting the sensor plug

- Strip back 30 mm of outer insulation (including any foil or braided screen)
- Assemble the cable and plug components as illustrated above **before** wiring the sensor.

- Wire the sensor to the plug according to the sensor type. Use a crimp connector or twist the sensor wires. Do not solder-tin the wires because they can come loose over time when used with screw clamp terminals.
- Tighten the threads between parts A & B before tightening the gland on the cable B & D. Use the correct rubber seal (C) to suit the cable diameter.
- Tighten the gland gently using a wrench – finger-tightened glands are not tight enough.

When making up the connectors, ensure that the connectors bodies are correctly threaded, and the cable seal is tight. Incorrectly assembled connectors will allow water in, which can permanently damage the sensor.

Vented cables

Cables from pressure-based water-level sensors are usually ventilated to allow for barometric pressure correction. A thin vent tube runs the length of the cable interior.

The Hydro-Logic® Flexi Logger 105 sensor connectors are vented to atmosphere via a Gore protective membrane. The membrane exposes the sensor vent tube to atmospheric moisture, while blocking liquid water. The sensor connector has loose terminal pins which allow barometric pressure to pass from the sensor vent tube, through both mating connectors and out through the Gore membrane. There is no need to drill the sensor connectors.

When installing, cut off the vent tube and unused conductors about 10mm beyond the end of the outer insulation. Do not crush the end of the vent tube.

SDI-12 sensors

SDI-12 sensors are “smart” sensors which can measure multiple parameters in engineering units using the industry-standard SDI-12 protocol.

An SDI-12 sensor uses 3 wires and is connected to the Flex Logger 105 sensor connector as shown.

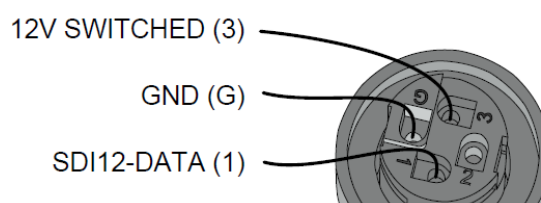

Sensor address

Before you can read an SDI-12 sensor, you need to specify the sensor address by configuring the logger with Harvest. Follow the steps in [Connecting the device](#) to ensure that you can communicate with the logger.

First, you need to find the address of the sensor. Ensure that there is only one sensor connected to the logger.

From Harvest, run the command **Start Wizard/Advanced logger options/SDI-12/Request Sensor Address:**

When an SDI-12 sensor is detected on address 0 the following output will be displayed:

```
Send sdi12RequestAddress Local
[09 Feb 2018 12:37:54]XDQ starting
Opening COM3
Initialising SDI-12...
?!
?!
?!
0
Initialised SDI-12 OK
Requesting SDI-12 sensor address...?!
0
Found sensor at SDI-12 address 0
```

Now you can test the sensor by reading it using that address. Run the command **Start Wizard/Advanced logger options/SDI-12/Request Measurements from Sensor:**

```
Send sdi12NonConcurrent Local
[09 Feb 2018 12:42:26]XDQ starting
Opening COM3
Initialising SDI-12...
0!
0!
0!
0
Initialised SDI-12 OK
Requesting measurements...
0M!
00012
0D0!
0+0.03967+20.4001
0M!
00012
0D0!
0+0.03864+20.4035
```

If you see measurements in the log above, the sensor is working OK.

When you configure the logger for this sensor, you need to specify this address in the SDI-12 tab:

Enabled	Description	Current Value	Units	Calibration	Alarms
<input checked="" type="checkbox"/>	TempC	16.85	DegC	<input type="checkbox"/>	<input type="checkbox"/>
<input checked="" type="checkbox"/>	TempF	62.33	DegF	<input type="checkbox"/>	<input type="checkbox"/>

SDI-12 Sensor Address:

Channel Disabled

Interval:

You also need to specify which parameters you want to log, with the Enabled check boxes.

While you are here, check the Calibration box and ensure that the “Range From” and “To” values include the range of measurements you are likely to see. If they do not, you will get gaps in your data when the sensor is outside this range.

TempC ×

Offset:

Units:

Decimals:

Range From: Resolution (at least):

Range To:

Calibration Type:

SDI-12 sensor warm-up time

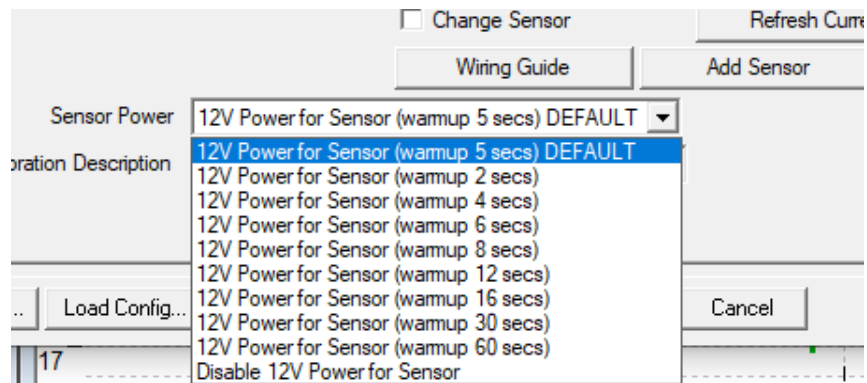

SDI-12 sensor warmup time can be modified from the default of 5 seconds for Flexi Logger 105 firmware version 2.39 or later.

(Requires Logger firmware 2.39 or later and Harvest 3.9.4 or later)

Addressing multiple SDI-12 sensors

Follow the above procedure to address and test each sensor. Give each a unique address, starting at 0.

When you are configuring the logger, use the Add Sensor button in the SDI-12 tab. It will create a new SDI-12 tab, and you can set the address of each sensor:

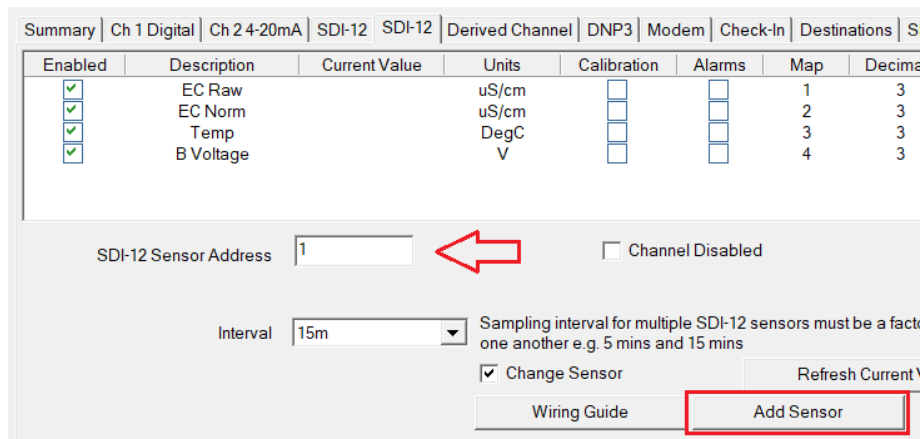

Wiring multiple SDI-12 sensors

Multiple SDI-12 sensors share the same 3 wires on the Hydro-Logic® Flexi Logger 105 sensor connect. They must be wired neatly for reliable performance on site.

Hydro International offers two products to help with this:

Two Sensors

If you have two sensors, a CA-SPLITTER (part no **PDA9100.1005**) can be used to neatly connect them to the logger.



The two connector leads are different lengths, so the connectors can both fit inside the steel tubing below a [PT enclosure](#). Use Size 8 Key Clamp so there is enough space for both sensor cables.

The CA-SPLITTER can be used with vented sensor cables.

An extra 4-way sensor connector is included with this part.

More than two sensors, or sensors needing external power

If you have more than two sensors, or sensors that need continuous external power, Hydro International offer a junction box specifically designed for connecting multiple sensors to the Hydro-Logic® Flexi Logger 105. This is part number **PDA1100.3020**

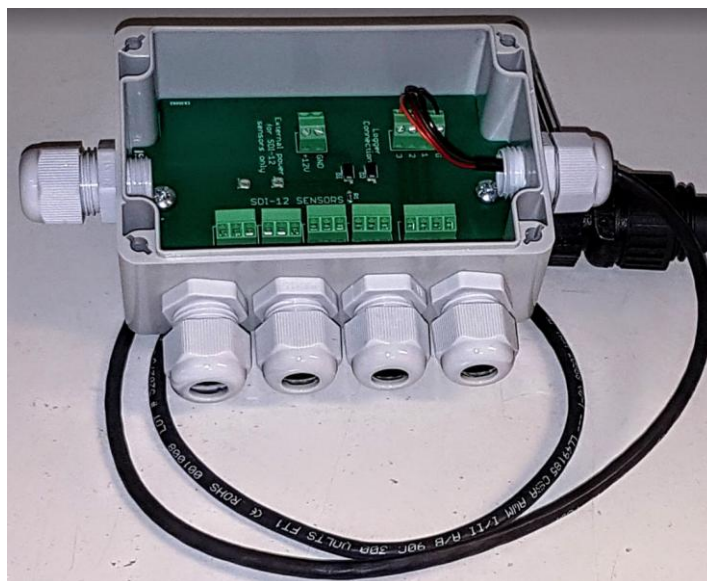

This junction box has clearly labelled PCB connectors and an option for external sensor power.

This junction box is too large to fit inside a PT Enclosure.

Power for SDI-12 sensors

The Hydro-Logic® Flexi Logger 105 provides 12V power for sensors. Up to 120mA current is supplied – the total for all connected sensors must not exceed this.

Sensor power is not continuous – it is switched on 5s before sensor activation. Additional warm-up is provided as requested by the sensor.

Most SDI-12 sensors work with switched power, but some require a continuous 12V supply. In this case, an external battery or DC power supply must be provided. Consult documentation supplied with the sensor.

4-20mA sensors

The Hydro-Logic® Flexi Logger 105 has one 4-20 mA input with 12V switched power up to 120mA. It can be used for either loop-powered or 3-wire 4-20mA sensors.

Loop powered sensors are wired as shown below. If there is a vent tube, cut it off inside the connector body and ensure it is not blocked.

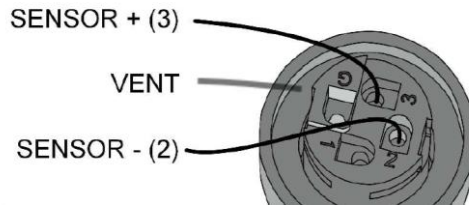

Process signals, where the loop is powered, should be wired as shown. A loop isolator should be used.

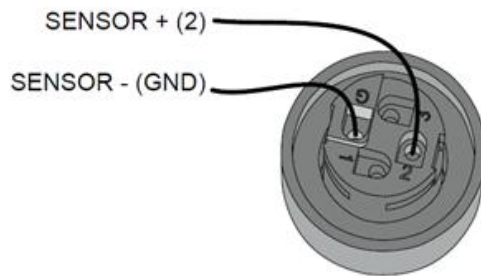

The sensor is powered for a user-specified warm-up period before a measurement is taken. Long warm-up periods will reduce battery life.

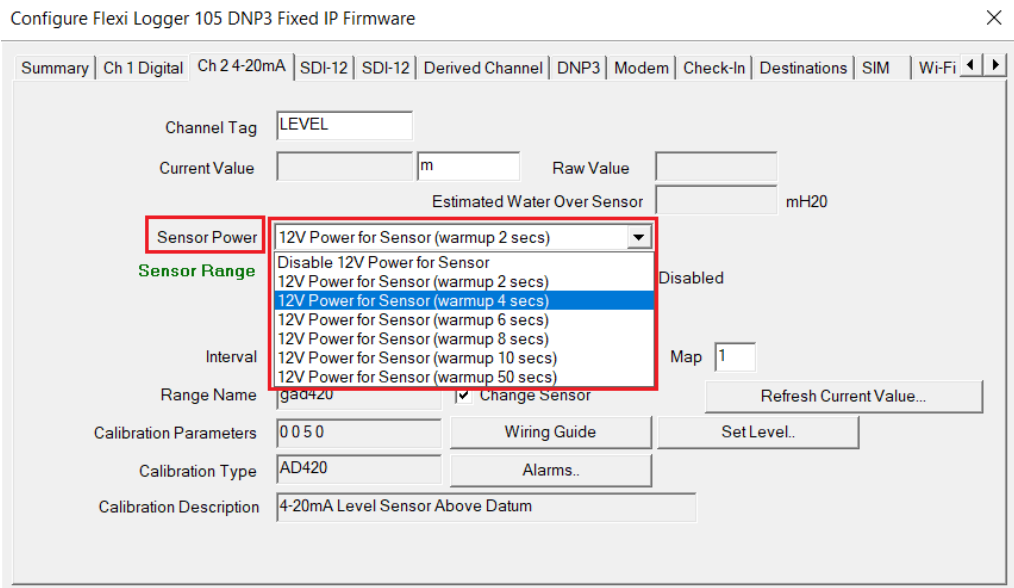

Tipping-bucket rain gauges

Tipping bucket rain gauges and other digital sensors use a “volt-free contact”. These types of sensors should be wired as shown below. Use a length of screened cable and connect the screen to the G terminal. Do not connect the screen to anything at the sensor end.

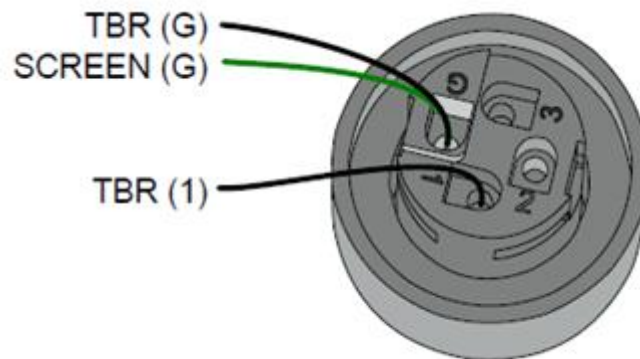

If an SDI-12 sensor is using pin 1 for data, you can use the second digital input on pin 2. If you do this, the 4-20mA input will not be available.

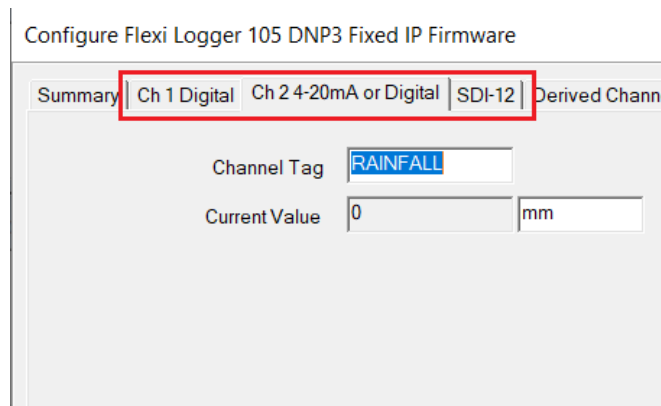

Approved sensors

Hydro International have a list of approved sensors which can be supplied with the Hydro-Logic® Flexi Logger 105. See the [Support website](#) for further information.

If you have a sensor in one of the above categories which is not on the Hydro International list, it may still be possible to use it. Please contact [Sales enquiries](#) to discuss support for a specific sensor.

Pre-wiring and configuration service

Experienced technicians will pre-wire and configure your sensors for you and ensure data is transferred successfully to Timeview if you have ordered this package.

This service **does not** include advanced alarm configuration, other setup or system design services. Contact [Sales enquiries](#) for further information.

Outdoor siting

If the Hydro-Logic® Flexi Logger 105 is sited outdoors, it **must be mounted in an enclosure** to protect it from vandalism, theft and prolonged direct exposure to the environment.

The external enclosure does not need to be sealed but should be sturdy and lockable or use security fasteners.

The Hydro-Logic® Flexi Logger 105 is rated for temporary immersion but should not be located anywhere that might be underwater for extended periods.

Pole top enclosure

The Hydro International **PT Enclosure** (part no **PDA1100.3065**) is a compact “pole top” outdoor enclosure designed for the Hydro-Logic® Flexi Logger 105. The enclosure is made of GRP (fibreglass) and stainless steel and allows mobile data signals to pass out from the internal antenna.

Do not mount an external antenna inside the PT enclosure. If you use one, it should be routed outside the PT enclosure with an extension cable and mounted in an elevated position.

The enclosure is designed to attach to a length of 43-50mm galvanized steel tube. Size 8 “Key Clamp” is ideal. These fittings are economical and versatile and allow a wide range of site-specific installations. The tube can also be used for sensor protection in many cases. Note that tubing and fittings are not included with the enclosure.





Example PT enclosure installations

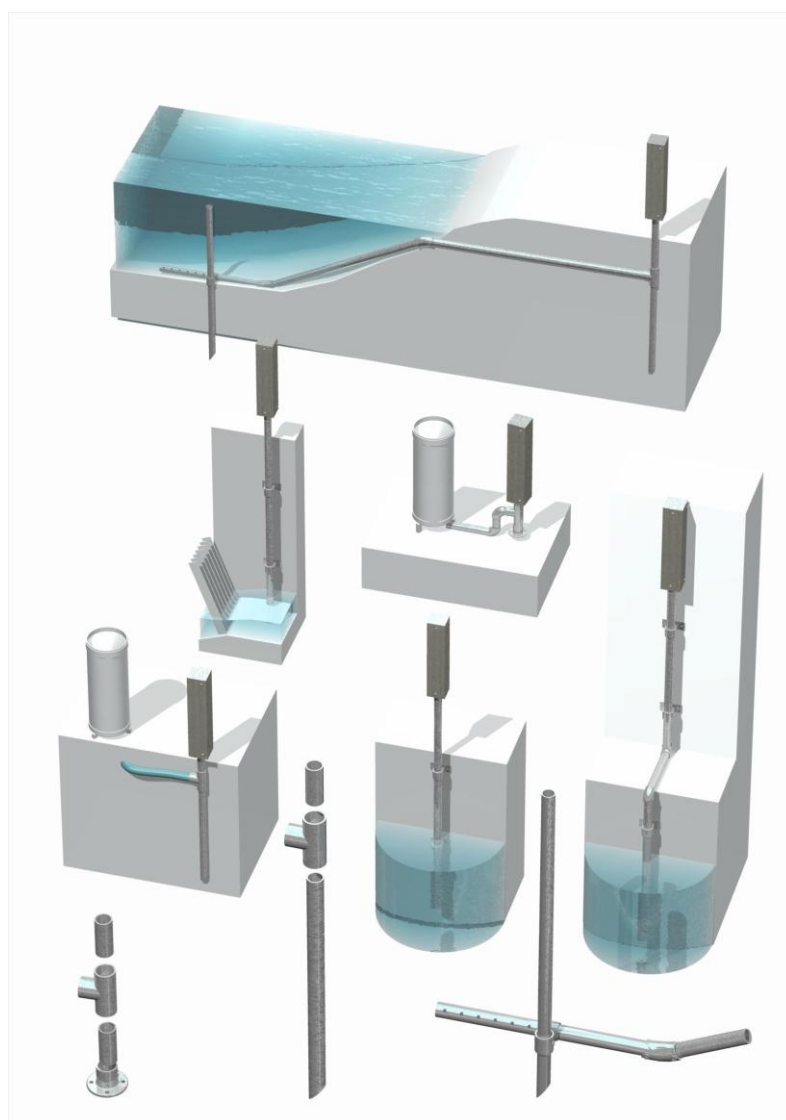

Antennas

The Hydro-Logic® Flexi Logger 105 has an **internal antenna**, which under normal conditions is the best choice.

There is also a connector for an external antenna which can be used in more challenging signal conditions. The external antenna must be mounted outside of all enclosures.

Examples of conditions that may require an external antenna:

- Installing the logger in a metal enclosure, kiosk or cabinet.
- Installation in remote sites with weak network coverage.

External antennas for metal enclosures

If the logger is inside a metal enclosure, a low-profile “teacake” antenna (part no **PDA9100.3315**) is recommended, which mounts in a **25mm diameter** hole in the top of the enclosure. It is secure and tamper resistant if mounted correctly.

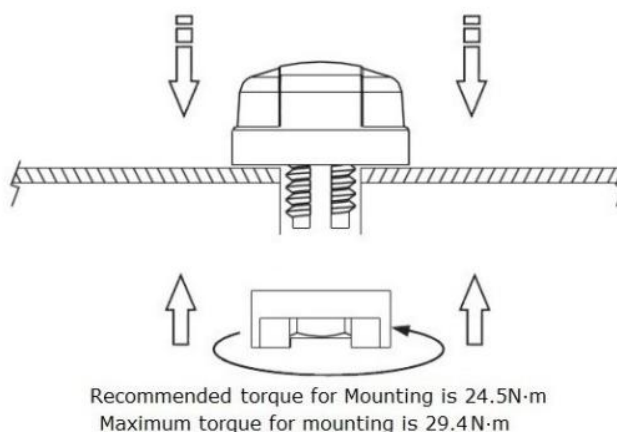

Other external antennas

Whatever type of external antenna you choose,

- Ensure the antenna matches the frequency requirements for mobile data. Choose a “Penta-band cellular antenna”. Do not use Wi-Fi or GPS antennas – they are not the correct frequency.
- Ensure the antenna cable connector suits the antenna socket on the Flexi Logger – the antenna cable must have an **SMA plug connector**.
- Do not locate the antenna beside metalwork or cables – it needs to be in the open, or surface mounted, depending on the antenna type.
- Avoid areas where the antenna may be overgrown with vegetation.



The external antenna connector is fitted with a sealing cap to protect the connector when not in use. **If an external antenna is not used, the cap must be fitted to protect the antenna connector.**

Other types of antenna are possible, depending on site conditions. Hydro International can provide advice and equipment based on years of installation experience. Please contact [Sales enquiries](#) for further details or to discuss specific requirements.

The default configuration for the Hydro-Logic® Flexi Logger 105 in Harvest is to use the Internal Antenna. If you want to use an External Antenna you must select the *External Antenna* option on the *Modem* tab in Harvest.

SIM cards

The Hydro-Logic® Flexi Logger 105 uses mobile data for telemetry and needs a correctly provisioned SIM to be installed and active.

Within the UK, Hydro International supplies complete [Timeview](#) packages including a roaming SIM, web-based Timeview data collection and alarm forwarding options. Please contact [Sales enquiries](#) for further details on Timeview packages.

If you have ordered this package, the SIM will be pre-installed.

Using your own SIM

Many clients successfully use their own SIMs with the Hydro-Logic® Flexi Logger 105. Both Private APN and fixed-IP SIMs can be used. You can still use Timeview with your own SIM, but you must purchase an “Own SIM” Timeview package.

The following points are important if you are using your own SIM:

- The SIM must be data enabled.
- Roaming SIMs are recommended

- A contract SIM is recommended because pre-pay SIMs are difficult to manage in remote devices.
- All SIM passwords must be disabled – you may need to put the SIM in a mobile phone to do this.
- Confirm the APN, Username and Password from the SIM provider and configure the logger with these via the GPRS tab in Harvest.
- For NB-IoT and Cat-M1 you also need to set the preferred networks and LTE bands to match your network providers and country.

SIM installation

This work must be undertaken in a dry, dust-free environment. Avoid touching the contacts on the SIM.

To change the SIM in the Hydro-Logic® Flexi Logger 105:

- Remove the lid by unscrewing the 8 spring-loaded retaining screws. Use a Pozidriv #1 screwdriver.
- Ensure the lid seal is retained in the cover.
- Lift the battery out to expose the SIM holder. You can leave the battery connected.
- The SIM holder is a hinged type. Slide the metal bar to the left to unlock the holder, and open it as shown:

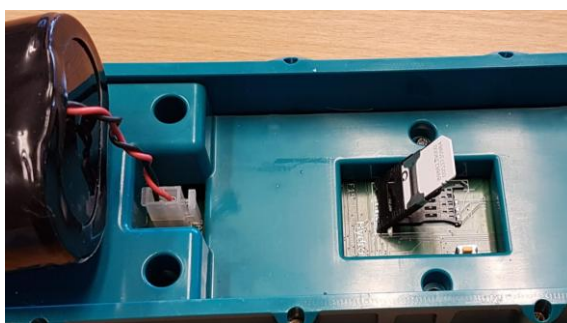

- The SIM must be correctly oriented (see below). Slide the SIM under the metal bar and close the holder, sliding the metal bar to the right to lock it.



- Put the battery back in its tray, as shown below:



- Replace the lid, ensuring the seal is properly seated in the groove. Lid screws should be finger-tight, tightened with a Pozidriv #1 screwdriver to 0.4 N·m, (3.5in lbf).

Access technology

The modem on the Hydro-Logic® Flexi Logger 105 supports dual mode Cat M1/NB1 (NB-IoT) with 2G fallback.

The default access technology in Harvest for the Hydro-Logic® Flexi Logger 105 is **GPRS Only** (2G). If the SIM card supports NB-IoT or Cat-M1 technologies and the technology is available where the logger is being installed, then they can be selected using the Preferred Technology setting on the *SIM* tab.

Configure Flexi Logger 105 DNP3 Fixed IP Firmware

SDI-12 | Derived Channel | DNP3 | Modem | Check-In | Destinations | SIM | Wi-Fi | FTP | System Alarms | Advan

APN: stream.co.uk
Username: streamip
Password: streamip

Get APN settings for your mobile network operator

1st Preferred Network: Vodafone (Contract) [Edit] [Clear]
2nd Preferred Network: O2 (PAYG) [Edit] [Clear]

Preferred Technology: NB-IoT with GPRS fallback
GPRS Only
CAT-M1 with GPRS fallback
NB-IoT with GPRS fallback
CAT-M1 (preferred) and NB-IoT with GPRS fallback
NB-IoT (preferred) and CAT-M1 with GPRS fallback

LTE Bands: [Dropdown]
Fixed IP Listen Port: [Dropdown]

The last Access Technology used by the logger is reported along with the Antenna that was used (Internal or External) on the Modem Tab

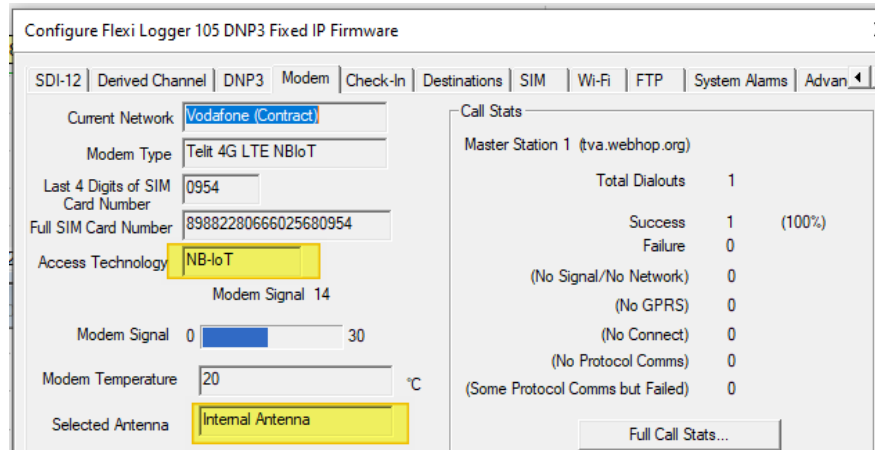

NB-IoT and Cat-M1

If your SIM supports NB-IoT or Cat-M1, then you should select the Preferred Technology option on the SIM tab according to which technology you would prefer the logger to use.

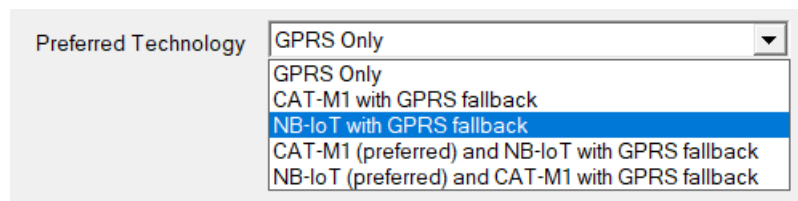

If both NB-IoT and Cat-M1 are available, then the Preferred Technology selection dictates which one is preferred.

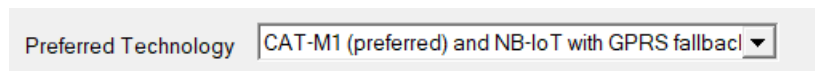

For roaming SIM cards capable of NB-IoT or Cat-M1, if you want to use NB-IoT or Cat-M1 on a particular network then you must select the Preferred Network that you want to use NB-IoT or Cat-M1 on. **Ensure you use the correct country for the preferred networks.**

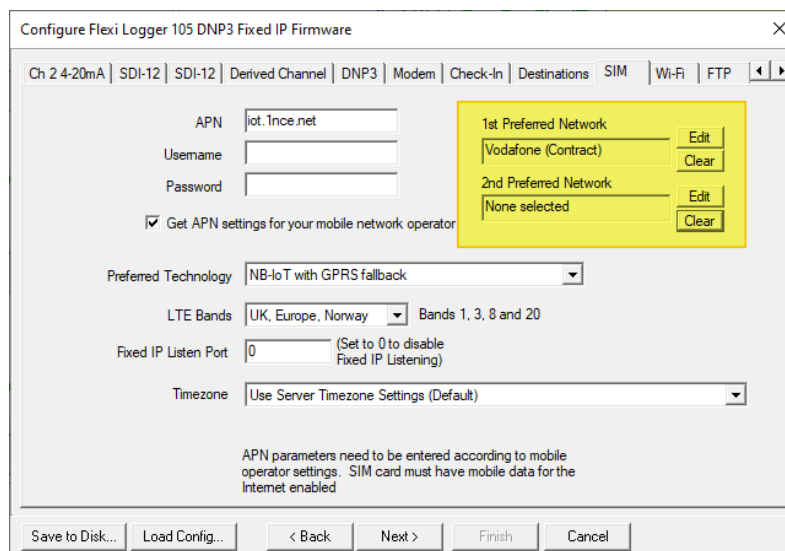

The first registration using NB-IoT or Cat-M1 can take a few minutes. This is normal and is due to the way the network authenticates the first NB-IoT or Cat-M1 registration. The time taken to register on first registration will vary depending on your network. Subsequent registrations will be much quicker.

For a single network SIM, if it is not registering using NB-IoT or Cat-M1 you should select the SIM network as Preferred.

You should also ensure that the LTE Bands are correct according to your region. You may need to check with your carrier to see which LTE bands are supported. Selecting too wide a range of bands will lead to increased registration and connection times.

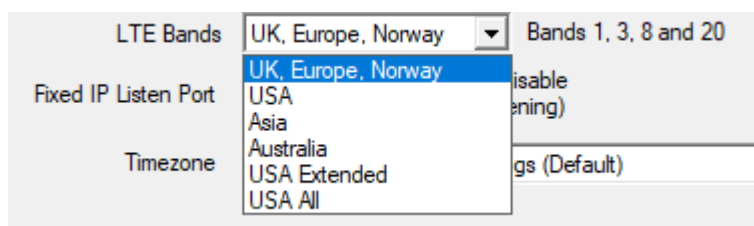

Batteries

Internally, the Hydro-Logic® Flexi Logger 105 requires a Lithium or Alkaline battery pack. *They are different from the batteries used by the Flexi Logger 100.* You should fit batteries anyway, even if using external power. They are a useful backup and will not be consumed while external power is present.

Battery part numbers:

PDA1100.3875 Flexi Logger 105 Lithium Battery Pack CPS2439

PDA1100.3905 Flexi Logger 105 Alkaline Battery Pack CPS2476



Replacing the batteries

This work must be undertaken in a dry, dust-free environment.

To change the batteries of the Hydro-Logic® Flexi Logger 105:

- Remove the lid by unscrewing the 8 spring-loaded retaining screws. Use a Pozidriv #1 screwdriver.
- Ensure the lid seal is retained in the cover.
- Lift the battery out, then unplug the connector by pressing the tab and gently pulling out:
- Remove the tape from the connector on the new battery pack, press the connector in until the tab clicks and locks in place, then seat the battery in the well.
- Replace the lid, ensuring the seal is properly seated in the groove. Lid screws should be finger-tight, tightened with a Pozidriv #1 screwdriver to 0.4 N·m, (3.5 in lbf).

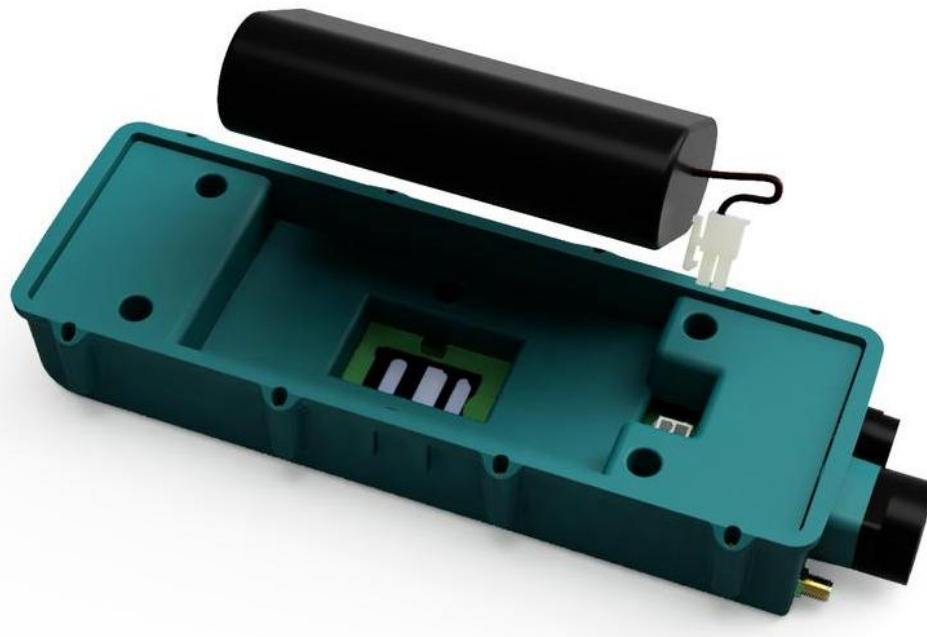
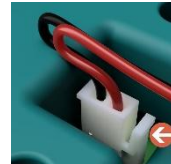

Lithium battery regulations

Though widely used, most people are not aware that lithium batteries are dangerous goods that can pose a safety risk if not packaged in accordance with the transport regulations and disposed of in the correct way.

Transportation

Cells used in the Hydro-Logic® Flexi Logger 105 battery pack are the LSH20 inorganic lithium metal cells manufactured by Saft. They contain **approx. 3.8g of lithium per cell**. There are 4 cells in each battery pack. See link below for UK guidelines on shipping lithium batteries:

<https://cellpacksolutions.co.uk/support/battery-regulations/>



These batteries are classified as Class 9 Dangerous Goods and are subject to regulations **UN3090** (Lithium Metal Batteries) and **UN3091** (Lithium Metal Batteries Contained in Equipment).

They must be packaged securely and labelled as shown, along with the UN3090 or UN3091 designation:

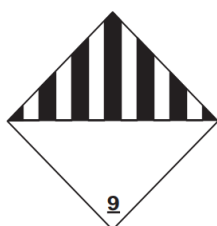

Class 9 hazard label,
reduced size,
black on white



Handling Label
"Cargo Aircraft Only",
reduced size,
black on orange

They must not be taken on passenger aircraft.

Disposal

Disposal should be done in accordance with the applicable regulations which vary from country to country. In most countries trashing of used batteries is forbidden and disposal is done via regulated waste disposal companies.

Batteries should not be incinerated unless suitable procedures are followed, and qualified handlers have taken appropriate precautions. Exposure of these cells to high temperatures or fires can cause the cells to vent or rupture.

Used batteries should be shipped with the same regulations as those for new batteries.



External power

The Hydro-Logic® Flexi Logger 105 can use a 12V battery or DC supply in the range of 9–24V. This will require the purchase of a Hydro-Logic® Flexi Logger Power Cable, part number **PDA1100.3100**



The external power cable shares the COM port, so it must be removed to use local comms. Power Cables are supplied with tinned bare wire at one end and must fit crimp terminals to suit the battery or supply. The colour of the wire insulation determines which are the positive and negative wires.

- Brown is positive (+)
- Blue is negative (-)

An internal battery should still be fitted when using external power. Provided the external power supply voltage is greater than the battery voltage, the battery will not be consumed.

The external power voltage is shown on the Harvest and Timeview displays.

Magnet

The small magnet included in the logger box can be used for triggering dial-outs and WiFi if it is held very close to the magnet symbol on the logger enclosure.

The beeper will provide feedback:

One beep	Trigger a dial-out
Two beeps	Turn on WiFi Hotspot
Four beeps	Turn sensor power on for 10 minutes

Larger magnets can be used to trigger WiFi and dial-outs without opening a [PT Enclosure](#). Slide the magnet slowly down the middle of the front side (the side with no screw holes) until you hear the logger beep.

A suitable magnet for this is the [F4MA48M8-EYE-1](#) (shown below), which is available in the UK and Europe from First4Magnets and other sites if you search for the part number above.



Configuration with Harvest Software

This is a limited guide on connecting the logger to Harvest. Further information is available in the Harvest Software Advanced User Manual, which can be downloaded from the [Support website](#).

Harvest overview

Harvest software is used to read and configure the range of Hydro-Logic® Flexi Logger devices. It is also used to export and manage data retrieved from these devices.

Harvest software is available in two versions

- Harvest for Windows based PCs
- Pocket Harvest for Windows Mobile based devices

You can download Harvest Windows software free of charge from our [Support website](#).

Install Harvest using the default options. If you have an older version of Harvest on your PC, you should install the newest version. Harvest supports older logger versions, but new loggers will not work with old versions of Harvest.

Connecting the device

To read or configure the Hydro-Logic® Flexi Logger 105 locally with a Windows PC you will need a copy of Harvest software and one of the following Serial Communications cables:

- USB Logger Cable (part no. **PDA1100.3090**)
- RS232 logger cable (part no. **PDA1100.3085**)



USB

RS232

Connect your serial cable to your PC and to the comms connector (6) on the logger:



Start Harvest and select Start Wizard/Read logger:

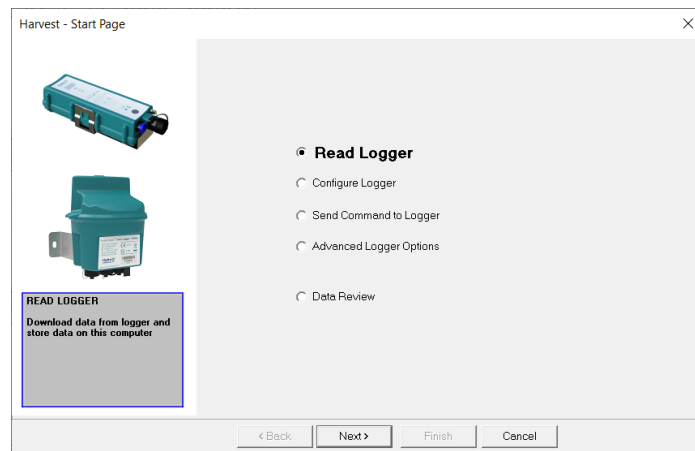

Press Next twice, selecting the default options Data Since Last Download and Local.

Now select the COM port that the serial cable is using. If you are using a USB cable, choose the port labelled *Hydro-Logic® USB Communications Cable*.

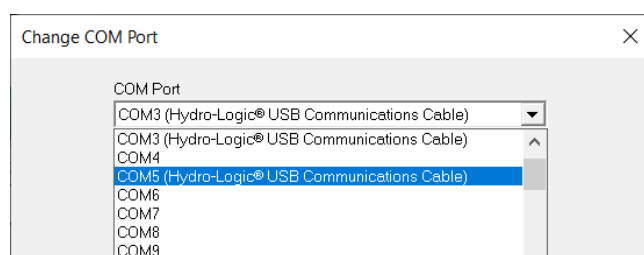
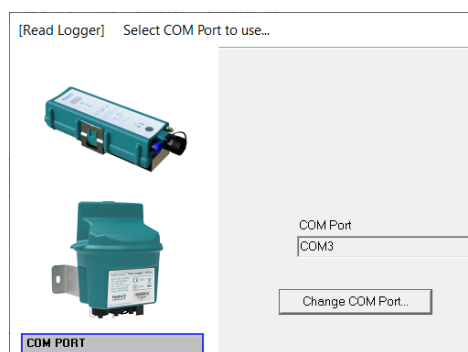

Press Next again and Harvest will read the logger. You should see blue and red flashes on the logger status LED, and messages in the log on Harvest:

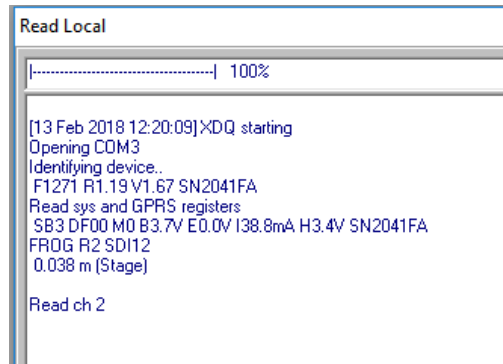

Once the command finishes, one or more data traces will be displayed:

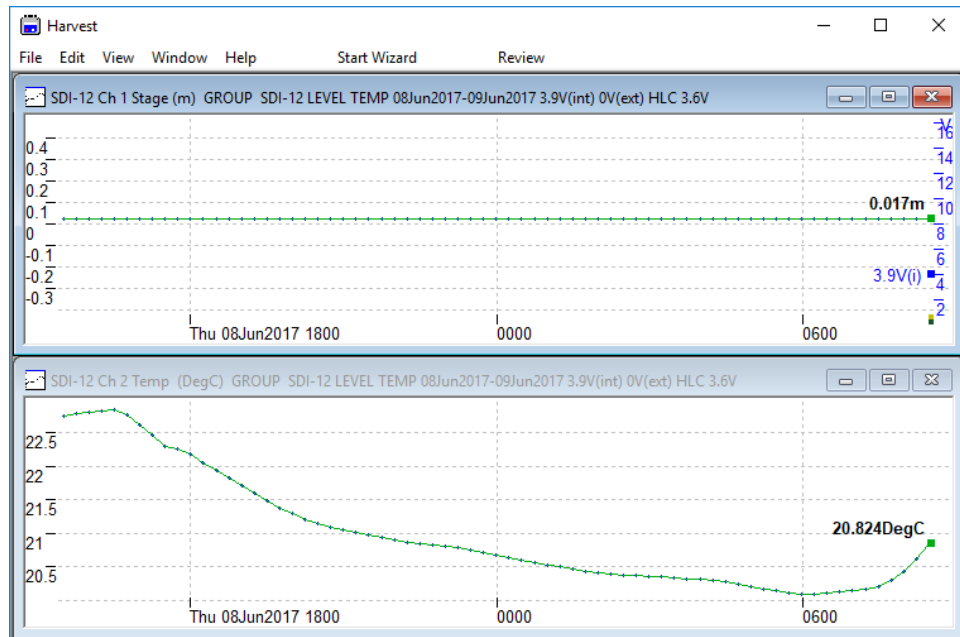

Connecting via Wi-Fi

If you have a Wi-Fi-enabled laptop with Harvest, you can read the Flexi Logger 105 wirelessly via “Wi-Fi Hotspot”.

To do this

1. Hold a [magnet](#) near the magnet symbol on the front of the logger until you hear **two beeps**. If the enclosure is open, you can alternatively hold the dial-out button (under the battery pack) until you hear two beeps.



2. On your laptop, display the available Wi-Fi networks. The logger should appear along with its serial number.
3. Connect to this network. The first time you do this, you will need to enter the password flexilogger. After you connect, you should see this:
4. From Harvest, select Read or Configure as normal. Instead of selecting

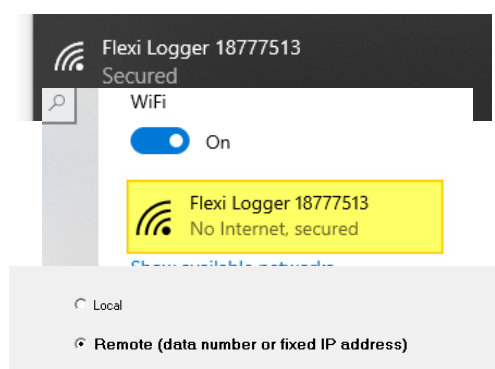

Local, select Remote fixed IP address:

5. Enter the IP address 192.168.4.1 and port number 2000 in the boxes that follow:
6. You can now access the logger normally, although Wi-Fi Check-In will not work because you are using the Wi-Fi module for local access.

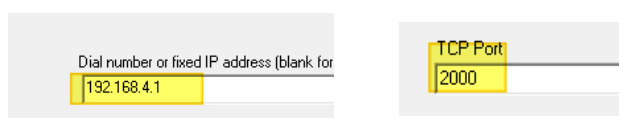

7. The Wi-Fi hotspot will time out after 10 minutes and switch off. Repeat the above procedure if you need more time.

Triggering a dial-out

You can cause the logger to call the telemetry server by selecting the Trigger Dial Out to Master Station command from the Start Wizard page.

This will switch on the modem and call any configured master station, which will read data from the logger.

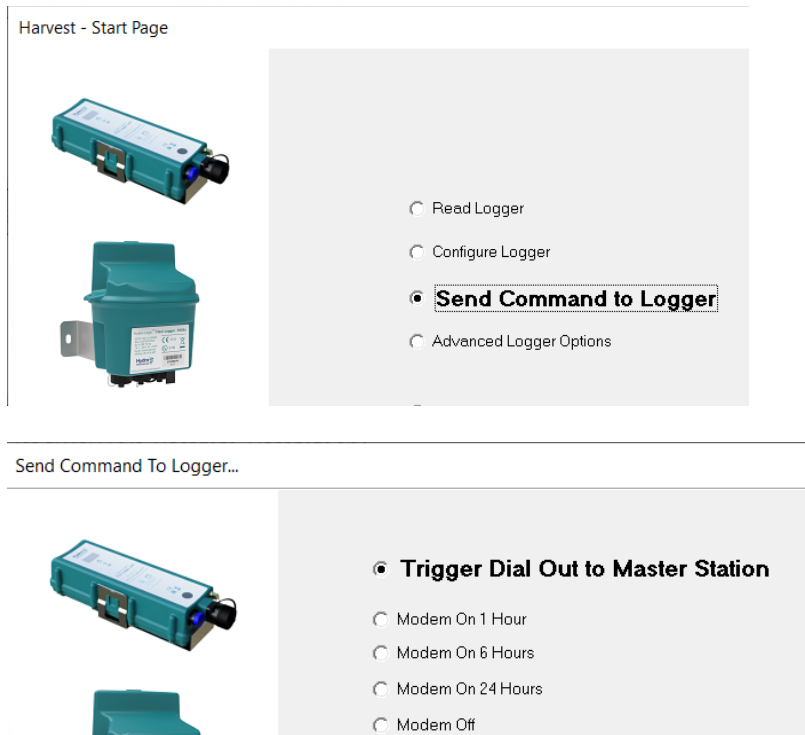

Resetting the logger clock with Harvest

Once you have read the data from the logger, right-click anywhere on either plot and select Configure to access the logger configuration:

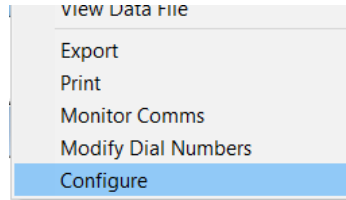

The logger configuration box has tabs which relate to different parts of the logger configuration. For now, ignore them and hit Next 3 times.

Configure Flexi Logger 105 DNP3 Fixed IP Firmware

Summary | Ch 1 Digital | Ch 2 4-20mA or Digital | SDI-12 | Derived Channel | DNP3 | Modem | Check-In | Destinations | SIM | Wi-Fi

Group: FLEXI LOGGER 105
 Tag: DIGITAL AND SDI12

Logger Type: Flexi Logger 105
 Firmware Version: 2.19
 Phone Number:
 Comms Duration: 4 secs
 Alarms: 0

Serial Number:
 Enclosure:
 PCB: 18777711

Channels In Use:
 Analog (A): 0
 Digital (D): 1
 SDI-12 (S): 2
 Derived (d): 0

Battery:
 Internal (Lithium): 5.1V
 External: 0V
 Battery Remaining: [Progress Bar]
 Current Consumption: 4.9mA

Telemetry:
 GPRS:
 Check-in Only
 Check-in 0400-0800
 Modem Signal 11
 0 [Progress Bar] 30

Ch	Description	Current Value	Raw Value	Mode	Interval	Stored	Capacity
	Not In Use						
1	RAINFALL	0mm	0	D	Accum	0	39900
2	TempC	17.72DegC		S	15m	1	39900
3	TempF	63.9DegF		S	15m	1	39900
	Not In Use						
	Not In Use						
	Not In Use						

Buttons: Save to Disk... Load Config... < Back Next > Finish Cancel

The configuration from the PC will now be sent to the logger. Although you have not changed anything, the new configuration will reset the logger clock and clear any time-series data that was stored in the logger.

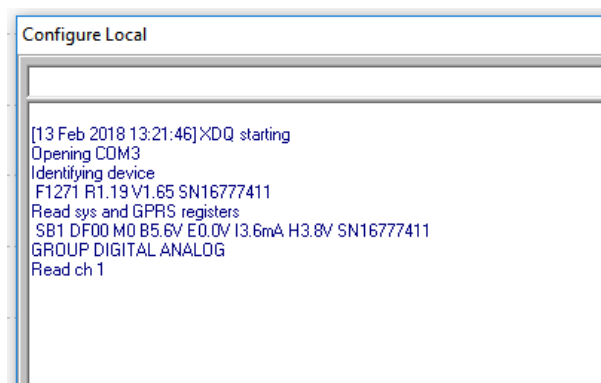

Basic configuration

Harvest can be used to change logger parameters using the same method as [Resetting the logger clock with Harvest](#)

The parameters are grouped into tabs in the configuration box. The frequently used ones are described here, the rest are in the separate Harvest manual available from the [Support website](#).

Logger Group and Tag

This is an information tab about the way the logger is configured and operating. You can also set the Group (1) and Tag (2) here. These values are important for identifying your site on Timeview.

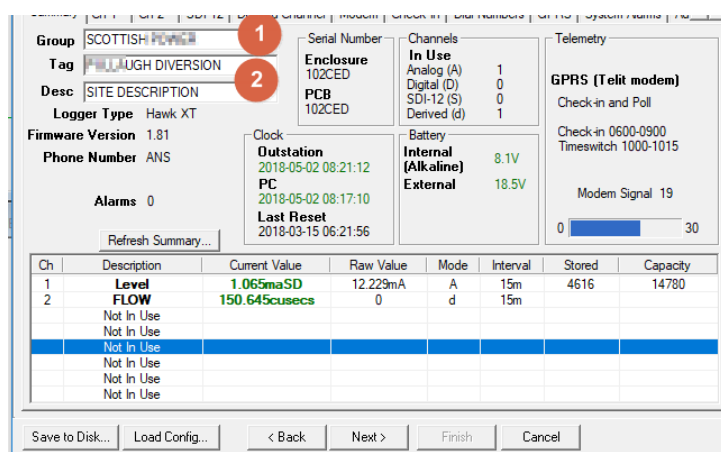

If you change the Group and Tag of the logger, it will start recording a new data series on Timeview. You should download and save any old data before you do this.

Configuring sensors

If you ordered the [Pre-wiring and configuration service](#), the logger will already be correctly configured for your sensor and you can skip this part.

These tabs are used for sensor configuration:

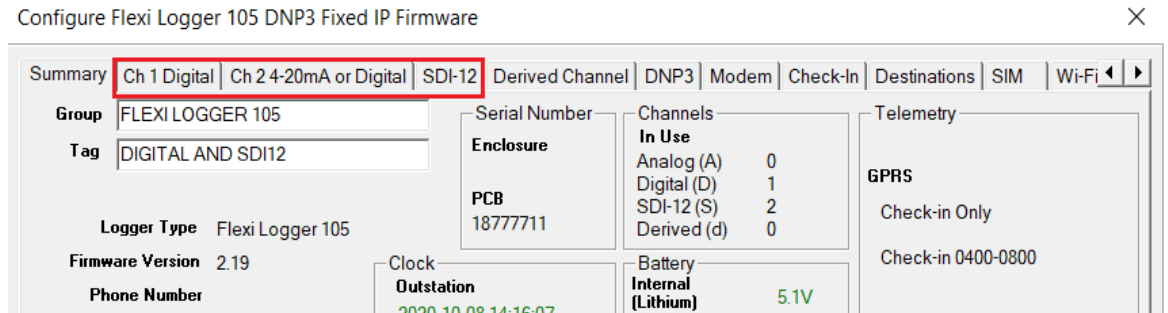

Press the Change Sensor tick box to access the list of applicable sensors for this channel:

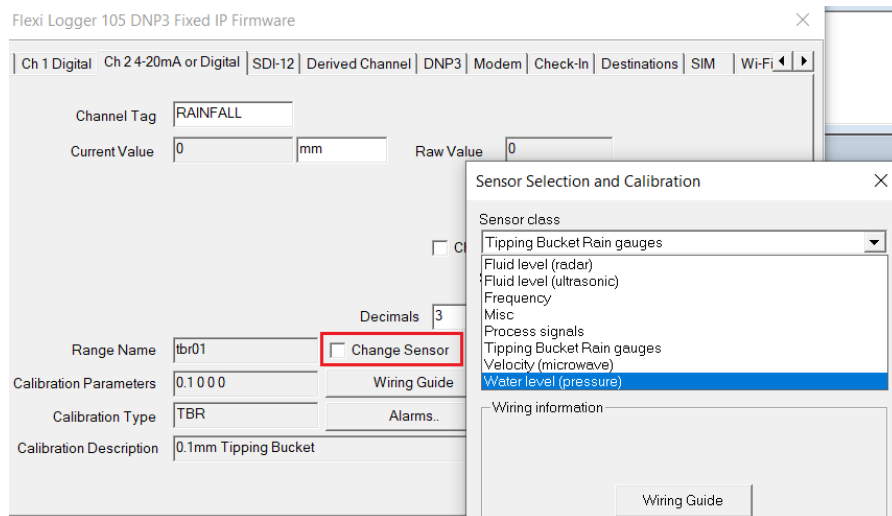

The drop-down list shows sensors that apply to this channel – they will be different if you are on an SDI-12 channel

Once the sensor is selected, you can configure it further, depending on the sensor type. See the section on [Sensors](#) for specific instructions.

Recording interval

You can change how often measurements are taken and stored by changing the Interval parameter:

Configure Flexi Logger 105 DNP3 Fixed IP Firmware

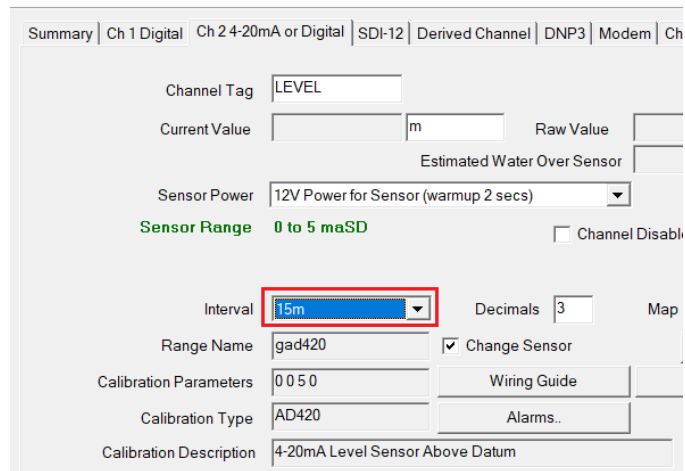

The screenshot shows the configuration interface for the Flexi Logger 105. The 'Interval' dropdown menu is highlighted with a red box and is set to '15m'. Other visible settings include 'Channel Tag' (LEVEL), 'Sensor Power' (12V Power for Sensor (warmup 2 secs)), 'Sensor Range' (0 to 5 maSD), 'Range Name' (gad420), 'Calibration Parameters' (0 0 5 0), 'Calibration Type' (AD420), and 'Calibration Description' (4-20mA Level Sensor Above Datum).

If you select intervals below 5m, you will shorten the battery life of the logger. 5m or 15m are used typically.

Water level with respect to datum

Water level can be measured with respect to an arbitrary datum without having to determine the level above the sensor. The Hydro-Logic® Flexi Logger 105 and Harvest software automatically determine the sensor depth and apply the datum offset during configuration.

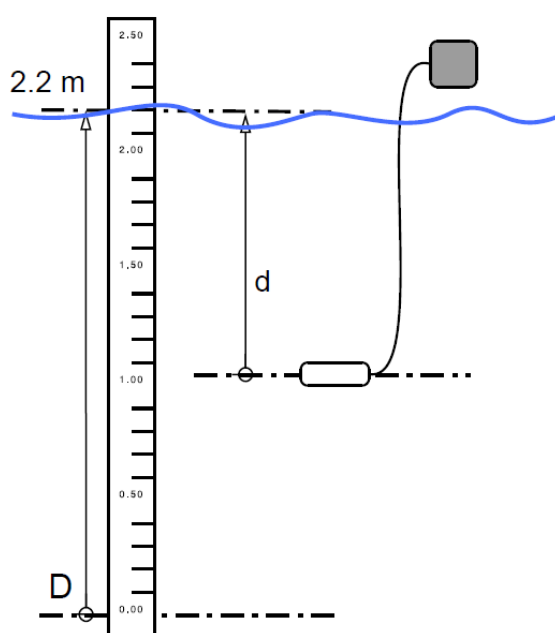

In the example above, the water is 2.2m deep with respect to arbitrary datum D. The sensor is only d (1.2m) deep in the water, but when the level is set, the offset to the datum is automatically applied so the logger displays levels with respect to the datum (here 2.2m).



This method works for both SDI-12 and 4-20mA water level sensors. The raw value is also displayed, so it is still possible to determine the water level over the sensor.



Note that before you set the water level, you should **trigger a dial-out** to transfer data before the level was changed. Setting water level will erase the data on the logger.

Sending data to a server

Data can be sent to Timeview Telemetry, XDQ Server, a DNP3 Master Station or an FTP server.

Overview - Timeview

Hydro-Logic® Timeview is a web-based telemetry data collection system. The following features are available

- receive data from the Hydro-Logic® Flexi Logger 105 and allows registered users of the site to view, download and export data from it
- alarm forwarding to alert groups of users
- review data and logger configuration in Harvest software
- remote clock synchronisation
- full remote configuration changes

Overview – Xdq Server

Hydro-Logic® Xdq Server is a data collection software package for either Windows Server or Linux. For more information, contact [Sales enquiries](#). The following features are available

- receive data from the Hydro-Logic® Flexi Logger 105
- review data and logger configuration in Harvest software
- remote clock synchronisation
- full remote configuration changes

The following features are not available

- Alarm forwarding

Overview - DNP3

The Hydro-Logic® Flexi Logger 105 can be configured to send its data to a DNP3 Master Station. The following features will typically be available (dependent on Master Station)

- clock synchronisation
- review of data in DNP3 Master Station
- alarm triggering
- remote configuration of certain parameters only

The following features will not be available

- review of data or configuration in Harvest software
- full remote configuration changes

Overview - FTP Transfer

The Hydro-Logic® Flexi Logger 105 can be configured to send its data to an FTP server. The following features are available

- automatic data transfer of CSV data
- transfer of certain logger status parameters including battery voltages

The following features will not be available

- clock synchronisation
- remote configuration changes
- review of data and configuration in Harvest software
- alarm forwarding, data processing and data visualisation (unless they are implemented by client)

Timeview via mobile data modem

Do not change the parameters here unless you are using your own telemetry server. The ones shown below work for Timeview.

Configure Flexi Logger 105 DNP3 Fixed IP Firmware

Ch 1 Digital | Ch 2 4-20mA | SDI-12 | SDI-12 | Derived Channel | DNP3 | Modem | Check-In | Destinations | SIM | Wi-Fi | FTP | S

			Server Port
Master 1 Primary	<input type="text" value="tva3.webhop.org"/>	<input type="checkbox"/> DNP3 <input type="checkbox"/> FTP	<input type="text" value="8443"/>
Master 1 Failover	<input type="text" value="tva3.webhop.org"/>	<input type="checkbox"/> DNP3 <input type="checkbox"/> FTP	<input type="text" value="9443"/>
Master 2 Primary	<input type="text"/>	<input type="checkbox"/> DNP3 <input type="checkbox"/> FTP	
Master 2 Failover	<input type="text"/>	<input type="checkbox"/> DNP3 <input type="checkbox"/> FTP	

[Change Server Ports...](#)

Timeview via local Wi-Fi

If you have a Wi-Fi network you can access from the logger site, you can configure the logger to check in using that.

You need to enter the Wi-Fi network credentials. See below:

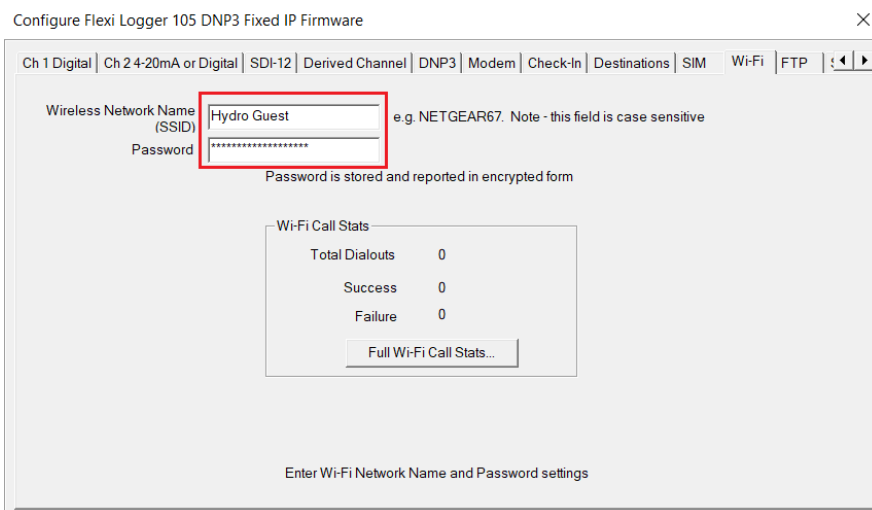

You need to enter the Destinations in the same way as for modem check-ins.

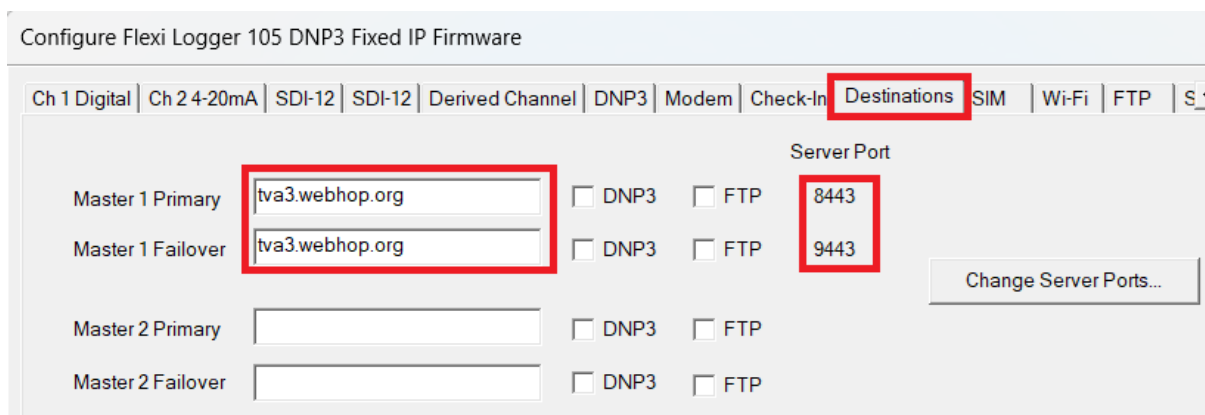

If site data is critical, you can also configure mobile data parameters. Wi-Fi will be tried first, and if this fails, the mobile data modem will be used.

Other data collection systems

DNP3

The Hydro-Logic® Flexi Logger 105 supports many SCADA systems that use the DNP3 protocol. Contact [Sales enquiries](#) to discuss your requirements and to get the DNP3 device profile documents for the Flexi Logger 105.

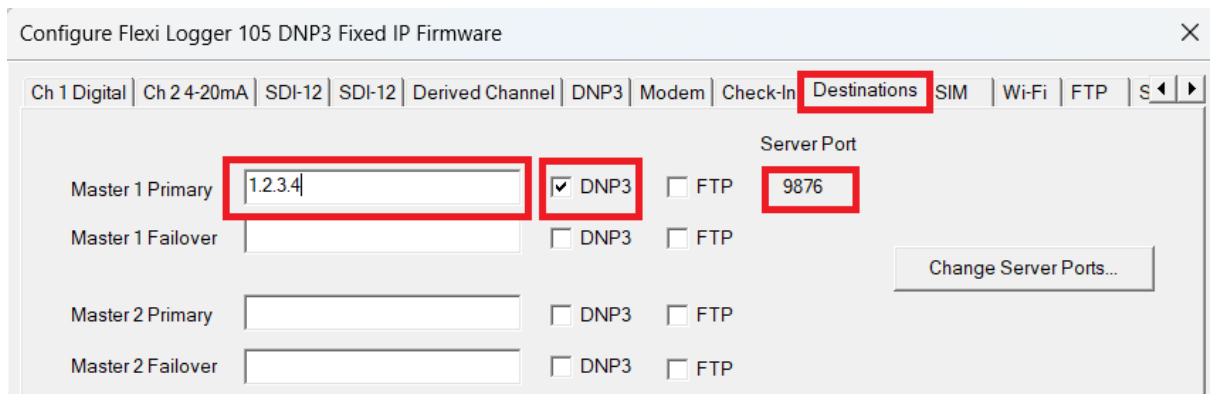

FTP Transfer

The Flexi Logger 105 can transfer data directly to an FTP server in CSV format.

This can only be done via the mobile data modem and is not possible with Wi-Fi data transfer.

To configure FTP transfer, set the username and password for the server login on the FTP tab.

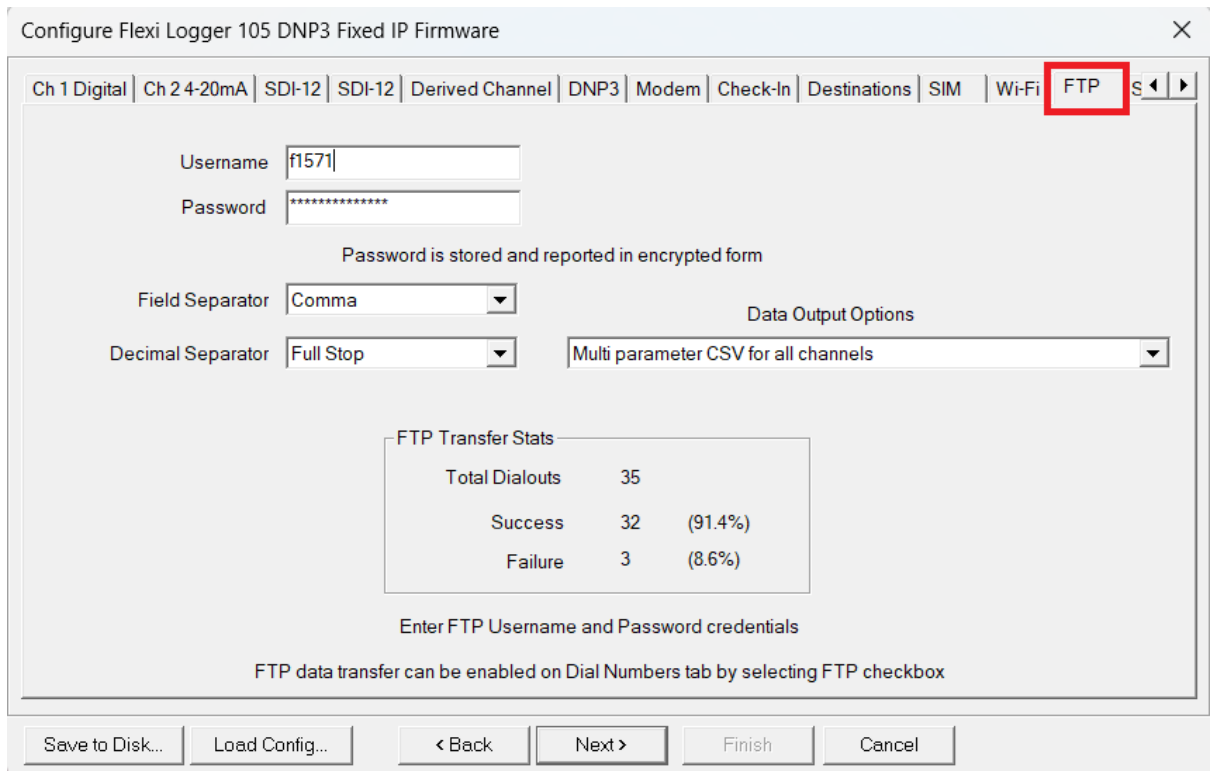

With logger firmware 2.56 or later, you can either select one **CSV file for each channel** or one **Multi parameter CSV for all channels** (see the *Data Output Options* selection). With firmware 2.54 or earlier, the default behaviour was one CSV file for each channel and there was no option to change that.

Then on the Destinations tab enter the FTP server IP or hostname and tick the FTP option. Select the Server Port as appropriate, usually port 21 for FTP.

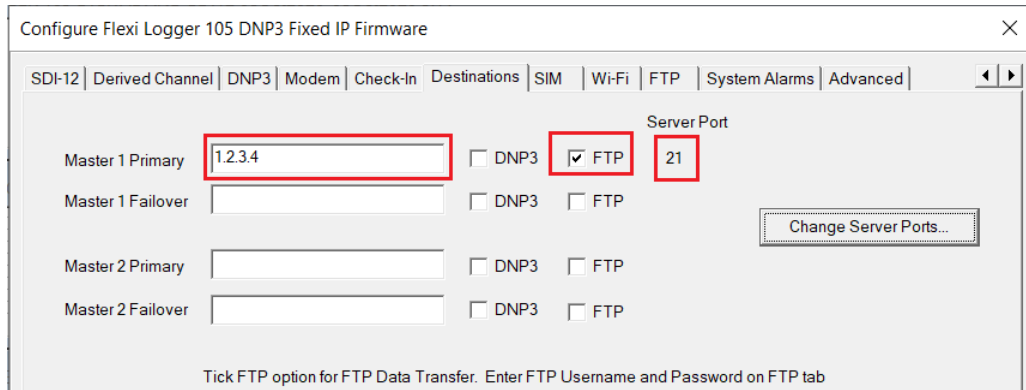

Then select the check-in frequency as normal, via the Check-In tab.

For the **CSV file for each channel** selection, the CSV files transferred are named with Group, Tag, date, and channel number – there is one file created for each channel, every time the logger checks in to the FTP server.

```

root@mailier:/home/fl1571
Logger tag:          SINGLE CHANNEL FTP,
Logger group:       FL105,
Serial number:      18778162,
Firmware version:   2.57,
SIM number:         89882280666132696752,
Internal battery:   5.7V,
External battery:   0.0V,
Battery remaining:  85.4%,
Modem signal:       21,
Average current:    7.0mA,
Channel no:         3,
Channel tag:        Perm5,
Sensor units:       pu,
2025-11-12T05:45:00Z,1.088
2025-11-12T06:00:00Z,1.045
2025-11-12T06:15:00Z,1.020
2025-11-12T06:30:00Z,1.082
2025-11-12T06:45:00Z,1.026
2025-11-12T07:00:00Z,1.044
2025-11-12T07:15:00Z,1.034
2025-11-12T07:30:00Z,1.072
2025-11-12T07:45:00Z,1.085
2025-11-12T08:00:00Z,1.056
2025-11-12T08:15:00Z,1.056
2025-11-12T08:30:00Z,1.077
2025-11-12T08:45:00Z,1.081
"FL105_SINGLE CHANNEL FTP_202511120948_3.csv" [dos] 30L, 828C
    
```

For the **Multi Parameter CSV for all channels** selection, the CSV file transferred are named with Group, Tag and date – there is one file created for all channels, every time the logger checks in to the FTP server.

```
root@mailier:/home/f1571 x + v
Logger tag: , FL105 FTP TEST,
Logger group: , FL105,
Serial number: , 18779419,
Firmware version: , 2.55,
SIM number: , 89882280666087879973,
Internal battery: , 5.1V,
External battery: , 0.0V,
Battery remaining: , 64.7%,
Modem signal: , 13,
Average current: , 1.8mA,
Channel no: , 1,2,3,4,
Channel tag: , Stage,Temp,Temp,Pressure,
Sensor units: , m,DegC,DegC,mbar,
2025-12-11T05:00:00Z,-0.103,18.819,18.240,0.275
2025-12-11T05:15:00Z,-0.103,18.829,18.240,0.275
2025-12-11T05:30:00Z,-0.103,18.819,18.240,0.275
2025-12-11T05:45:00Z,-0.103,18.819,18.240,0.275
2025-12-11T06:00:00Z,-0.103,18.819,18.230,0.275
2025-12-11T06:15:00Z,-0.103,18.819,18.230,0.275
2025-12-11T06:30:00Z,-0.103,18.810,18.230,0.275
2025-12-11T06:45:00Z,-0.103,18.810,18.230,0.275
2025-12-11T07:00:00Z,-0.103,18.800,18.230,0.275
2025-12-11T07:15:00Z,-0.103,18.819,18.230,0.275
2025-12-11T07:30:00Z,-0.103,18.810,18.230,0.275
2025-12-11T07:45:00Z,-0.103,18.810,18.230,0.275
2025-12-11T08:00:00Z,-0.103,18.810,18.230,0.275
"FL105_FL105 FTP TEST_202512120445.csv" [dos] 109L, 5091C
```

Automatic data transfer (mobile data modem)



The logger must be able to automatically transfer data to Timeview or your telemetry server when it is unattended on site. Provided it can do this, it can be reconfigured remotely to make other changes, so it is **very important that the logger is set up to transfer data automatically.**

The logger should have shipped pre-configured to do this, but you should check before you take it to site.

On the Check-in tab the Daily Check-in option is set. You must ensure that there is a range of times specified for the logger to check-in to Timeview. Do not leave them as 0000:

Configure Flexi Logger 105 DNP3 Fixed IP Firmware

Ch 2 4-20mA or Digital | SDI-12 | Derived Channel | DNP3 | Modem | **Check-In** | Destinations | SIM | Wi-Fi | FTP | Syst

Check-in to Server (Regular) Daily Check-in (Check-in Window must be set)

Check-in to Server (In Alarm Condition) On Alarm and Regular Check-in

Check-in Window

From 0000

To 0000

Check-in Window

From 0400

To 0900

More frequent data transfer

In this example below, more frequent check-in has been configured (1) – every 3 hours. This will increase average current consumption and reduce battery life.

It also increases the amount of data transfer, so you need to have an “Hourly” data package enabled on Timeview if you are using a SIM supplied by Hydro International. Contact [Sales enquiries](#) to arrange this.

Note that the logger will check in every 3 hours AND daily within the times specified on the Check-in Window. If you don't want the daily check-in, the window values should be both set to 0000.

Configure Flexi Logger 105 DNP3 Fixed IP Firmware

Ch 2 4-20mA or Digital | SDI-12 | Derived Channel | DNP3 | Modem | Check-In | Destinations | SIM | Wi-Fi | FTP | System Alarm

Check-in to Server (Regular) **Check-in every 3 hours** 1

Check-in to Server (In Alarm Condition) On Alarm and Regular Check-in

Check-in Offset UTC+0 e.g. Check-in every 12 hours with a UTC+4 hour offset gives check-ins of approximately 0400 UTC and 1600 UTC instead of 0000 UTC and 1200 UTC with no offset.

Check-in Window

From 0400

To 0900

SIM and time zone settings

If you are using your own SIM, you will need to change the parameters (1) so they match those required by the SIM provider. See [SIM cards](#).

You should set the local time zone (2) so that times are displayed with your correct local time on Timeview. Note that Daylight Savings or Summer time is not used by these loggers. They always display in local standard time.

The screenshot shows the 'Configure Flexi Logger 105 DNP3 Fixed IP Firmware' dialog box with the 'SIM' tab selected. The dialog has a tabbed interface with the following tabs: 'Ch 2 4-20mA or Digital', 'SDI-12', 'Derived Channel', 'DNP3', 'Modem', 'Check-In', 'Destinations', 'SIM', 'Wi-Fi', and 'FTP'. The 'SIM' tab contains the following settings:

- APN:
- Username:
- Password:
- Get APN settings for your mobile network operator
- 1st Preferred Network: (Buttons: Edit, Clear)
- 2nd Preferred Network: (Buttons: Edit, Clear)
- Preferred Technology:
- LTE Bands: Bands 1, 3, 8 and 20
- Fixed IP Listen Port: (Set to 0 to disable Fixed IP Listening)
- Timezone: (highlighted in yellow)

APN parameters need to be entered according to mobile operator settings. SIM card must have mobile data for the Internet enabled

Buttons at the bottom: Save to Disk..., Load Config..., < Back, Next >, Finish, Cancel

Timeview data collection and configuration

Timeview is a website hosted by Hydro International where data from the Hydro-Logic® Flexi Logger 105 can be displayed and downloaded. This way, you can monitor your site assets remotely, from your desktop.

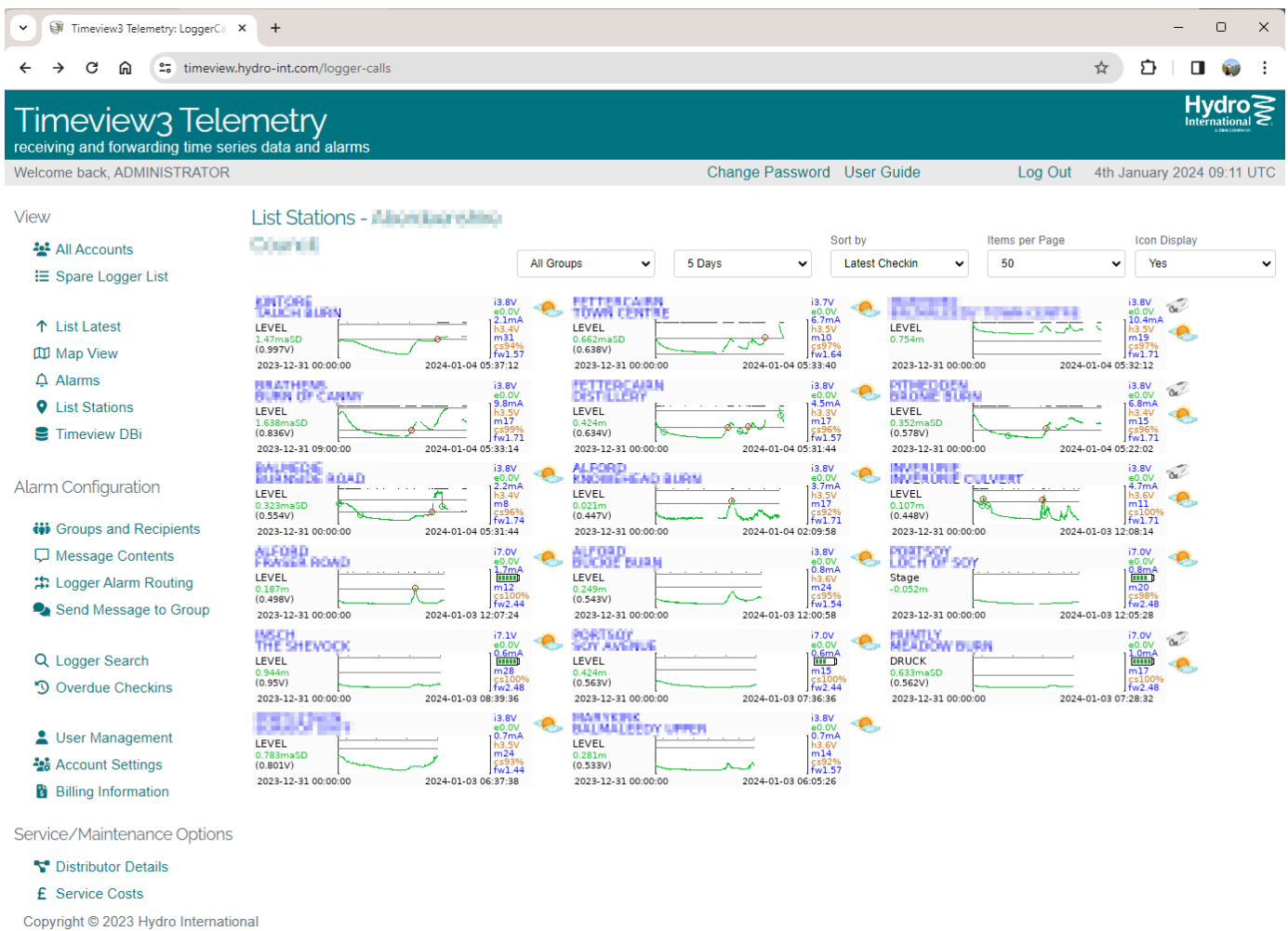

The website address is

<https://timeview.hydro-int.com/>

Finding your data on Timeview

*You should have received a *user name and password* for an account on Timeview. Go to this website and enter that user name and password.

Now go to the **Logger Search** option on the left side of the page. Enter the serial number from the logger cap, or from the delivery note or box label. Either is fine. Then press **Search**.

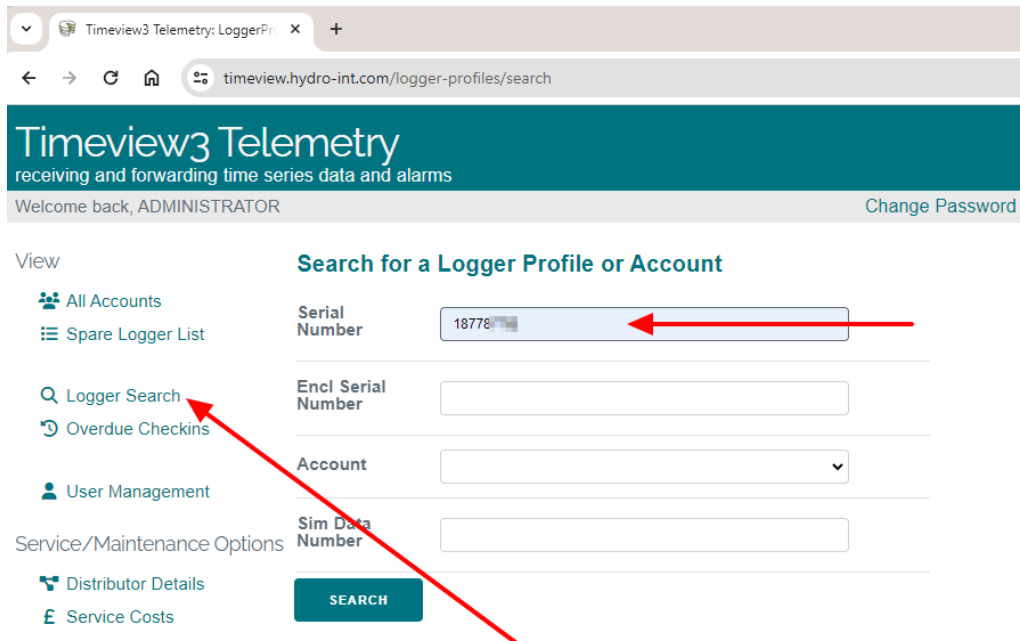

Your logger serial number should now appear in the Logger Profiles page. Press View.

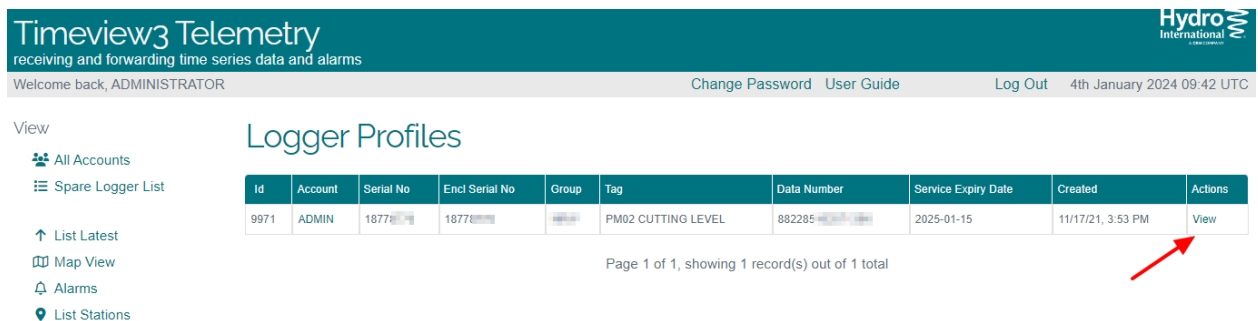

You should now see a page showing data from the logger. There will be no data there, because there is no sensor connected. The logger has been off, so the clock will not be accurate. Both faults are reported on the plot, which has a red border to indicate the error conditions.

The important field is the Last Checkin Details, which should be the time that the logger dialled in. Note that this is always Standard Time – Daylight Saving or Summer Time is not displayed on Timeview.

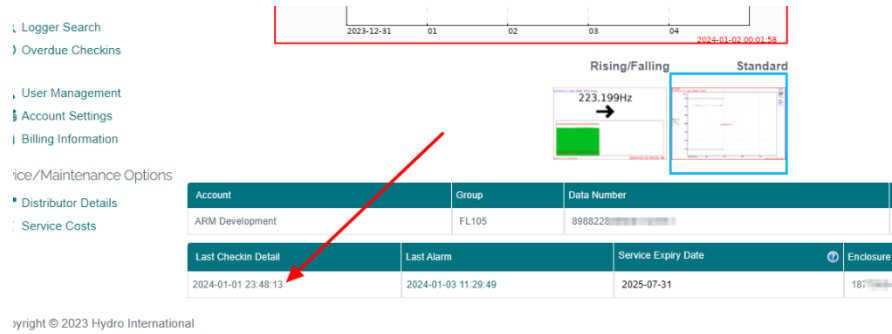

Resetting logger clock with Timeview

You can clear the clock error message and set the logger clock accurately using Timeview. Do this by selecting Configuration:

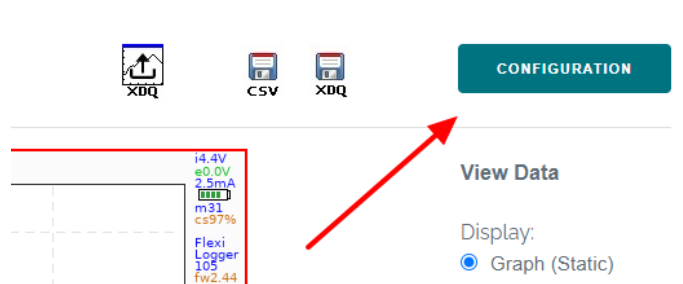

Then select Reset Logger Clock (and confirm you want to do this)

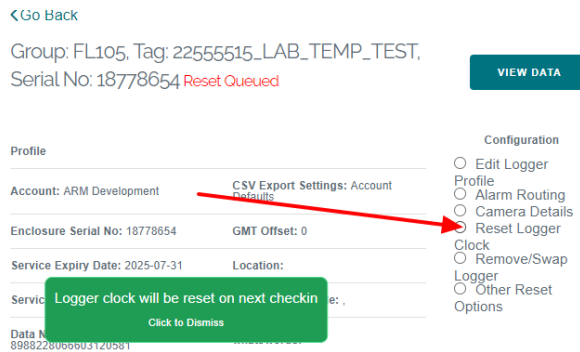

The next time the logger calls in, the clock will be reset:

Use the magnet or push the internal dial-out button (yellow flash/single beep) to trigger a call. After the logger LED goes back to a 2s blue flash, refresh the page on your browser. The clock error message should be cleared.

Alarms

As well as the regular calls to transfer data, **alarms** can be configured on the Hydro-Logic® Flexi Logger 105 so that certain site conditions are detected and trigger a data transfer to the telemetry server. Alarm information from site is then forwarded from Timeview to individuals or groups.

Harvest software is used for configuring alarms. There is also some setup required on Timeview. **Both the logger and Timeview configuration must be correct for alarms to work properly.**

Logger alarm configuration

The Alarms check box (1) is on the sensor tab:

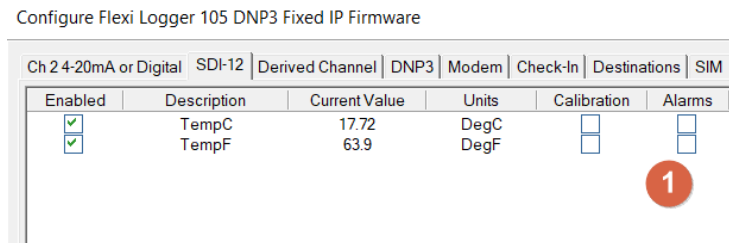

Once selected, you get the alarm config box:

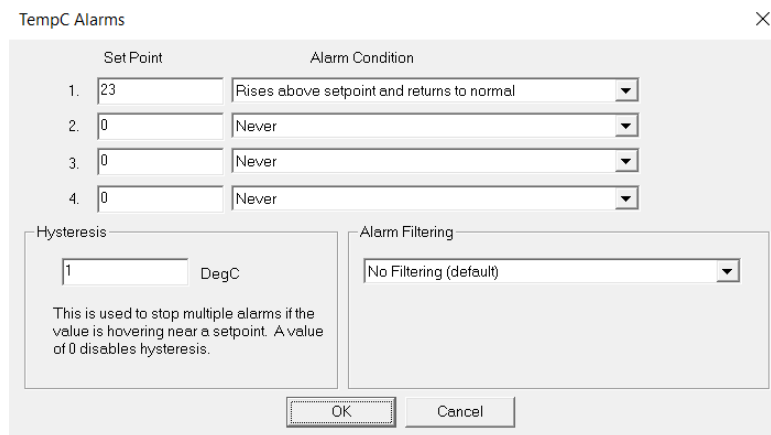

Set point and alarm condition

There are up to 4 alarms for every channel. The **Alarm Condition** field sets how the logger should react when the **Set Point** is crossed. Here, we want the logger to contact Timeview whenever the temperature exceeds 23 degrees, and when it returns to normal.

Hysteresis

This is used to prevent multiple alarms if the sensor value is near the set point. This parameter is shown as a grey bar on the plot:

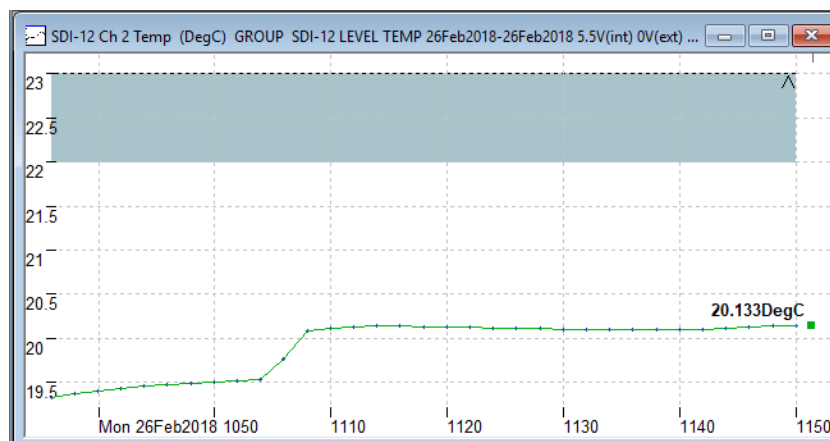

The temperature must rise above 23 degrees to trigger the alarm but *fall below 22 degrees* before the logger checks-in with a return-to-normal event.

The Alpha field can be used to provide some noise reduction in special circumstances but should normally be left as 0.

Provided the logger is transferring data to Timeview correctly, there is no more alarm setup required on the logger.

Once you have configured alarms on the logger, trigger a dial-out to Timeview so that the logger alarm configuration information is transferred. See [Connecting to Timeview](#).

Timeview alarm configuration

Groups and recipients

The logger calls Timeview when it detects an alarm condition. *It does not contact alarm recipients direct.* Timeview does that via the Groups and Recipients page (1). Create a New Message Group, here called Temperature test (2):

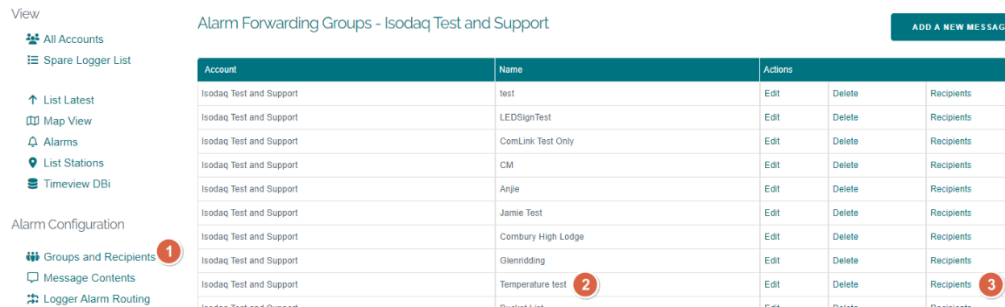

Then select Recipients (3) and add the names and either email addresses or SMS mobile numbers. You can add many recipients to each group.

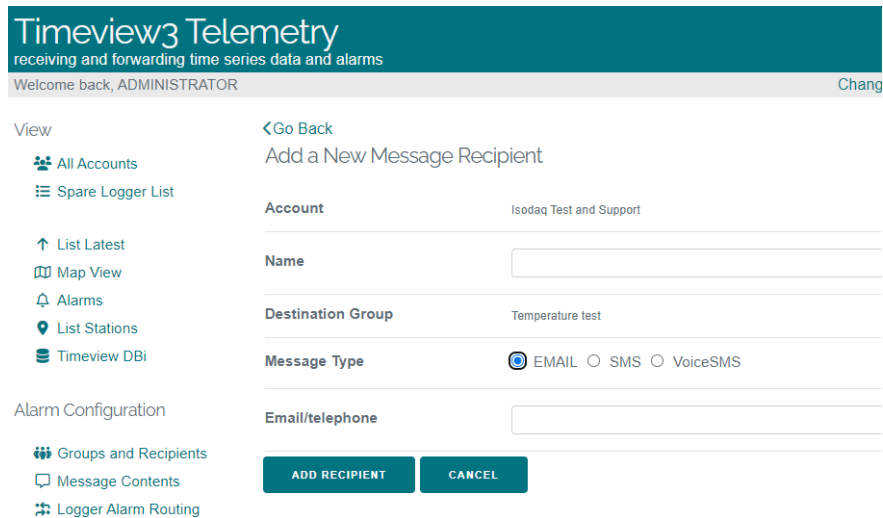

Note that SMS messages and Voice SMS messages are charged, and you must have credits for them on your Timeview account. Contact [Sales enquiries](#) to arrange this.

Message contents

The alarm call from the logger contains the channel number, set point and direction of the alarm (set, or return to normal). It does not contain descriptive information about what the alarm means. Timeview adds this information via the Message Contents page (1). Add a new message relevant to your alarm set point – here, “Probe too warm”.

Timeview DBI Alarm Configuration Groups and Recipients Message Contents 1 Logger Alarm Routing Send Message to Group Logger Search Overdue Checkins	Isodaq Test and Support	DN59180FF	Edit	Delete
	Isodaq Test and Support	Backup Timeview Test Alarm	Edit	Delete
	Isodaq Test and Support	Battery Low Warning	Edit	Delete
	Isodaq Test and Support	CRITICAL 25% LOW	Edit	Delete
	Isodaq Test and Support	DANGER 50% LOW	Edit	Delete
	Isodaq Test and Support	PRECAUTION 75% CHECK	Edit	Delete
	Isodaq Test and Support	Glenridding Alarm	Edit	Delete
	Isodaq Test and Support	Bucket Half Full	Edit	Delete
	Isodaq Test and Support	Probe too warm 2	Edit	Delete

Alarm routing

Locate your logger (see [Finding your data on Timeview](#)) and select Configuration (1):



On the Alarm routing page (1), you can see the alarm set point you configured on the logger (2):

Group: FL105, Tag: TEMPERATURE, Serial No: 18778759 VIEW

Channel or Battery Alarm Routing					
Channel	SetPoint	Group	Message	Test	Add/Del
Select	Select	Select	Select		+

Configuration

- Edit Logger Profile
- Alarm Routing
- Camera Details
- Reset Logger Clock
- Remove/Swap Logger
- Other Reset Options

Late Checkin Alarm Routing					
Late Checkin Notifications	Group	Message	Test	Add/Del	
	Select	Select			+

Logger Properties			
Server Date: 2024-01-09 16:03:40		Checkin Every 3 Hours 0400 0900	
Logger Date: 2024-01-09 16:03:40			
	Storage Interval	Hysteresis	Alarm SetPoints
Ch1 TempC(DegC):	1m	1	23.000 (Rises Above and Returns to Normal) 2
Ch2 TempF(DegF):	1m		

Use the drop-down selections to choose the channel, set point, group and message, then create the alarm with the green + symbol:

The top screenshot shows the 'Channel or Battery Alarm Routing' configuration table. The 'Group' dropdown menu is open, showing options: Select test, LEDSignTest, Bucket List, ComLink Test Only, Jamie Test, Anjie, CM, Cornbury High Lodge, Glenridding, and Temperature test. The 'Temperature test' option is highlighted.

The bottom screenshot shows the same table with the following configuration:

Channel	SetPoint	Group	Message	Test	Add/De
1	1	Temperature test	Probe too warm	+	✖
Select	Select	Select	Select		+

Configuration options on the right:

- Edit Logger Profile
- Alarm Routing
- Camera Details
- Reset Logger Clock
- Remove/Swap Logger
- Other Reset Options

The alarm should now appear in the list. Now you need to test it.

End-to-end testing

Testing of this sort is very important, so you can be confident that the alarms are correctly set up.

You should do it twice – once before you take the logger to site, and once after installation.

End-to-end means you are simulating the whole alarm process, from the measurement at the sensor to the receiver of the alarm.

For initial testing, you can set a faster Recording Interval to reduce the time required for the testing. Here, use Harvest to set a 1m Recording interval and let the logger record for a few points. Then simulate an alarm condition at the sensor, which may be a bucket of water for a level sensor, or in this case a cup of warm water.

Now wait until the alarm is triggered – you can tell because the LED on the logger will start flashing blue rapidly as the modem is switched on. This will start very shortly after a measurement is taken, and for 1m recording, this happens on the “cardinal points” of time – look at your PC clock for times like 10:01, 10:02, etc, assuming you used this PC to configure and reset the logger.

Once the logger has stopped flashing, you should receive the alarm email or SMS message almost immediately.

Look on Timeview, on the List Latest page. The alarm should appear at (1), while the thumbnail plot will show the alarm as a small red circle (2).

Latest Alarms - Isodaq Test and Support Remaining Alarm Credit 228

Group	Tag	Serno	Alarm Detail	Alarm Time	Received	Actions
FL105	TEMPERATURE	18778759	Probe too warm 1	2024-01-09 16:44:00	2024-01-09 16:44:47	View
FLEXI LOGGER 100	ALARM TEST	204215	Check-in Failure Alarm	2020-06-13 10:23:10	2020-06-12 10:47:18	View
FLEXI LOGGER 100	ALARM TEST	204215	Chan1: -0.000m Return to Normal	2020-06-12 10:46:00	2020-06-12 10:47:18	View
FLEXI LOGGER 100	ALARM TEST	204215	Check-in Failure Alarm	2020-04-15 10:23:36	2020-04-14 05:34:46	View
FLEXI LOGGER 100	ALARM TEST	204215	Check-in Failure Alarm	2020-04-13 10:23:38	2020-04-12 06:18:32	View

Latest Data - Isodaq Test and Support currently displaying 3 of 3

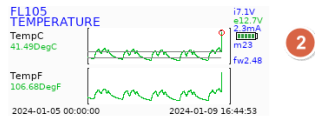

View the alarm to check the contents and delivery. You can see the alarm time stamps (1), the message recipients (2) and (for SMS messages) a delivery report to confirm if the message has been received by the recipient's phone (3).

Alarm

Serial No	Group	Tag	Alarm Detail	Alarm Time	Alarm Received
18778759	FL105	TEMPERATURE	Probe too warm 1	2024-01-09 16:44:00	2024-01-09 16:44:47

Message Type	Message	Recipient	Delivery Status	Credits
EMAIL	FL105 TEMPERATURE Probe too warm Alarm Setpoint: 1.23 Current Value: 41.4996 DegC Alarm Time: 2024-01-09 16:44:00 Received: 2024-01-09 16:44:47 Serial number: 18778759 Channel: 1 Chan Tag: TempC Battery: 7.1 12.7136	tcampbell@hydro-int.com 2		0
SMS	2024-01-09 16:44:00 FL105 TEMPERATURE Probe too warm	07765240416	4 - Message Delivered 3	1

Now remove the alarm condition and wait until the sensor drops below the alarm threshold (with Hysteresis, 22 degrees in this case). The logger will dial out again to report the return-to-normal event.

Viewing alarms on plots

The Graph (Dynamic) is the best way to view alarms on plots. You may need to refresh the page to see recent alarms (use ctrl-refresh to force a page update).

Alarms are shown as red circles on plots, while return to normal events are green. The set point is a red line, and the hysteresis band is grey:

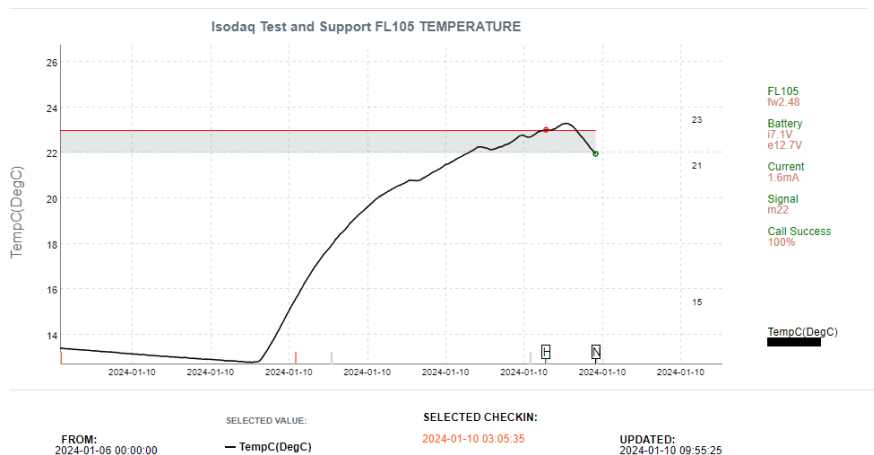

Maximizing battery life

You can maximize battery life by doing the following:

- Use a 5m or 15m storage interval for all channels. Shorter intervals will use significantly more power.
- Avoid sensors that require long warm-up times or have high current drain when they are active.
- Avoid long or frequent 'Time Switch' windows. Keep the modem on for as short a time as possible.
- Make only one call to the telemetry server per day. Frequent check-ins will reduce battery life. Configure alarms to make the logger check-in as soon as an alarm condition is detected, while daily calls show that the system is still in correct operation.
- Avoid low signal strength areas (modem signal on Harvest < 10). Fit an external antenna if necessary, to improve the signal, but don't use one if the internal antenna works well.

PSTI Statement of Compliance (SoC)

We, Hydro International Ltd, hereby declare that under our own responsibility that the device listed below complies with the applicable security requirements in **Schedule 1 of The Product Security and Telecommunications Infrastructure (Security Requirements for Relevant Connectable Products) Regulations 2023**.

Hydro-Logic® Flexi Logger 105 telemetry data logger

The above product is in conformity with the following Security requirements for manufacturers:

1. Passwords are protected with 2 Factor Authentication and specified by the user.
2. Users can report vulnerabilities to <https://www.hydro-int.com/en/smart-monitoring-support> Furthermore, users will receive acknowledgment of the receipt of a security issues report and status updates until the resolution of the reported security issues.
3. We will provide security updates for this product during the support period. The defined support period will end 5 years after the product's last end-of-life date.

EU declaration of conformity

1. Apparatus model/Product:

Hydro-Logic® Flexi Logger 105 telemetry data logger

2. Name and address of the manufacturer:

**Hydro International
Unit 2, Rivermead Court
Kenn Business Park
Clevedon, BS21 6FT**

3. This declaration of conformity is issued under the sole responsibility of the manufacturer.

4. Object of the declaration:

Hydro-Logic® Flexi Logger 105 telemetry data logger

5. The object of the declaration described above is in conformity with the relevant European Union harmonisation legislation:

- **Radio Equipment Directive (RED) 2014/53/EU**
- **Restrictions of Hazardous Substances (RoHS) Directive 2011/65/EU**

6. Applicable standards:

- **EN 61010-1:2010 +A1:2019**
- **EN 62311:2008**
- **EN 301 511 V12.5.1**
- **EN 50581:2012**

Signed for and on behalf of: Hydro International, Unit 2, Rivermead Court Kenn Business Park Clevedon, BS21 6FT

A handwritten signature in blue ink, appearing to read "Tim Campbell".

Tim Campbell, Principal Design Engineer

1 October 2025